

EtherCAT & Pulse Motion Controller

ZMC308E

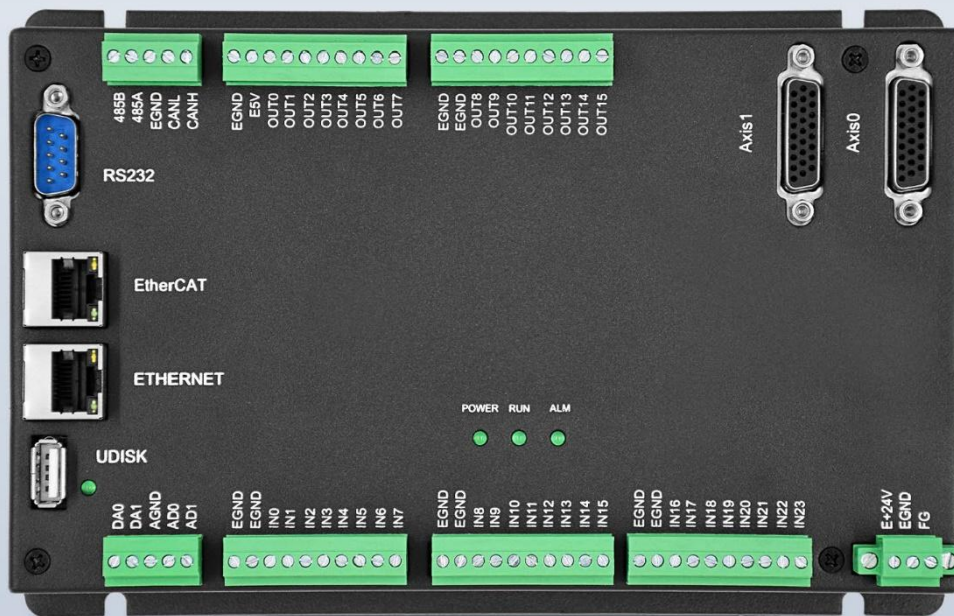

This manual is mainly for ZMC308E, ZMC304E, ZMC306E.

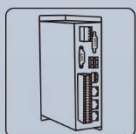

Vision Motion
Controller

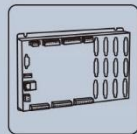

Motion
Controller

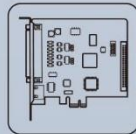

Motion
Control Card

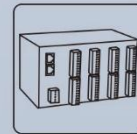

IO Expansion
Module



HMI

Statement

Thank you for choosing our Zmotion products. Please be sure to read this manual carefully before use so that you can use this product correctly and safely. Zmotion is not responsible for any direct or indirect losses caused by the use of this product.

The copyright of this manual belongs to Shenzhen Zmotion Technology Co., Ltd. And reproduction, translation, and plagiarism of any content in this manual in any form is strictly prohibited without the written permission of Zmotion.

The information in this manual is for reference only. Due to design improvements and other reasons, Zmotion reserves the right of final interpretation of this information! Contents are subject to change without prior notice!

➤ Notes

In order to prevent possible harm and damage caused by incorrect use of this product, the following instructions are given on matters that must be observed.

■ Danger

Do not use it in places with water, corrosive or flammable gases, or near flammable substances.	May cause electric shock, fire, damage, etc.
When installing or disassembling, make sure the product is powered off.	
Cables should be connected securely, and exposed parts that are energized must be insulated by insulators.	
Wiring work must be performed by professionals.	

■ Notes

It should be installed within the specified environmental range.	May cause damage, mis-operation, etc.
Make sure there are no foreign objects on the product hardware circuit board.	
After installation, the product and the mounting bracket should be tight and firm.	
After installation, at least 2-3cm should be left between the product and surrounding components for ventilation and replacement.	
Never disassemble, modify, or repair it by yourself.	

Content

Chapter I Production Information	5
1.1. Product Information	5
1.2. Function Features	5
1.3. System Frame	7
1.4. Hardware Installment	7
Chapter II Product Specification	10
2.1. Basic Specification	10
2.2. Model Selection	11
2.3. Interface Definition	12
2.4. Work Environment	13
Chapter III Wiring & Communication	14
3.1. Power Input	14
3.1.1. Power Specification	14
3.2. RS485, CAN Communication Interface	14
3.2.1. RS485, CAN Communication Specification & Wiring	15
3.2.2. Basic Usage Method	17
3.3. RS232, RS422 Serial Ports	18
3.3.1. RS232, RS422 Communication Interface Specification & Wiring	19
3.3.2. Basic Usage Method	20
3.4. IN Digital Input & High-Speed Latch & Single-ended Encoder	21
3.4.1. Digital Input Specification & Wiring	23
3.4.2. Basic Usage Method	24
3.5. OUT Digital Output, PWM Terminal, Hardware Comparison Output, Single-ended Pulse	25
3.5.1. Digital Output Specification & Wiring	26
3.5.2. Basic Usage Method	28
3.6. AD/DA Analog Input & Output	28
3.6.1. Analog Input / Output Specification & Wiring	29
3.6.2. Basic Usage Method	30
3.7. U Disk	31
3.8. ETHERNET	31

3.9.	EtherCAT Bus Interface	32
3.10.	AXIS Differential Pulse Axis Interface	34
3.10.1.	AXIS Interface Signal Specification & Wiring.....	36
3.10.2.	Basic Usage Method.....	38
Chapter IV Expansion Module		40
4.1.	CAN Bus Expansion	40
4.1.1.	CAN Bus Expansion Wiring	40
4.1.2.	CAN Bus Expansion Resource Mapping.....	42
4.2.	EtherCAT Bus Expansion	46
4.2.1.	EtherCAT Bus Expansion Wiring	46
4.2.2.	EtherCAT Bus Expansion Resource Mapping.....	48
Chapter V Programming		50
5.1.	Program in RTSys Software	50
5.2.	Upgrade Controller Firmware.....	55
5.3.	Program in Host-Computer by PC Languages.....	56
Chapter VI Operation and Maintain.....		59
6.1.	Regular Inspection and Maintenance	59
6.2.	Common Problems & Solutions.....	60

Chapter I Production Information

1.1. Product Information

ZMC is the abbreviation of the network motion controller model launched by Zmotion Technology.

ZMC308E high-performance multi-axis motion controller is a stand-alone motion controller that is compatible with EtherCAT and pulse type. The controller itself supports complex continuous trajectory control requirements of up to 12 axes.

ZMC3 series high-performance multi-axis motion controller can be applied in robots (SCARA, Delta, 6 joints), electronic semiconductor equipment (testing equipment, assembly equipment, locking equipment, soldering machine), dispensing equipment, non-standard equipment, printing and packaging equipment, textile and garment equipment, stage entertainment equipment, medical equipment, assembly line, etc.

1.2. Function Features

- ◆ Motion control of up to 12 axes.
- ◆ Pulse output mode: pulse / direction or dual pulses.
- ◆ The fastest refresh cycle of EtherCAT is 500us.
- ◆ Support encoder position measurement, which can be configured as handwheel input mode.
- ◆ Maximum pulse frequency output of each axis: 10MHZ.
- ◆ 4096 isolated inputs and 4096 isolated outputs can be extended at most through ZCAN bus and EtherCAT.
- ◆ Axis position limit signal / origin signal port can be configured as any input at will.

- ◆ The maximum output current of general digital outputs can reach 500mA, which can directly drive some kinds of solenoid valves.
- ◆ Interfaces: EtherCAT, RS232, RS485, RS422, U Disk, Ethernet.
- ◆ Support linear interpolation, any circular interpolation and helical interpolation of 12 axes at most.
- ◆ Support electronic cam, electronic gear, position latch, synchronous follow, virtual axis, etc.
- ◆ Support hardware comparison output (HW_PSWITCH2), hardware timer, precision output in motion.
- ◆ Support pulse closed loop, pitch compensation and other functions.
- ◆ Multi-file and multi-task programming in RTBasic.
- ◆ A variety of program encryption methods to protect the intellectual property rights of customers.
- ◆ Power failure detection and power failure storage.

1.3. System Frame

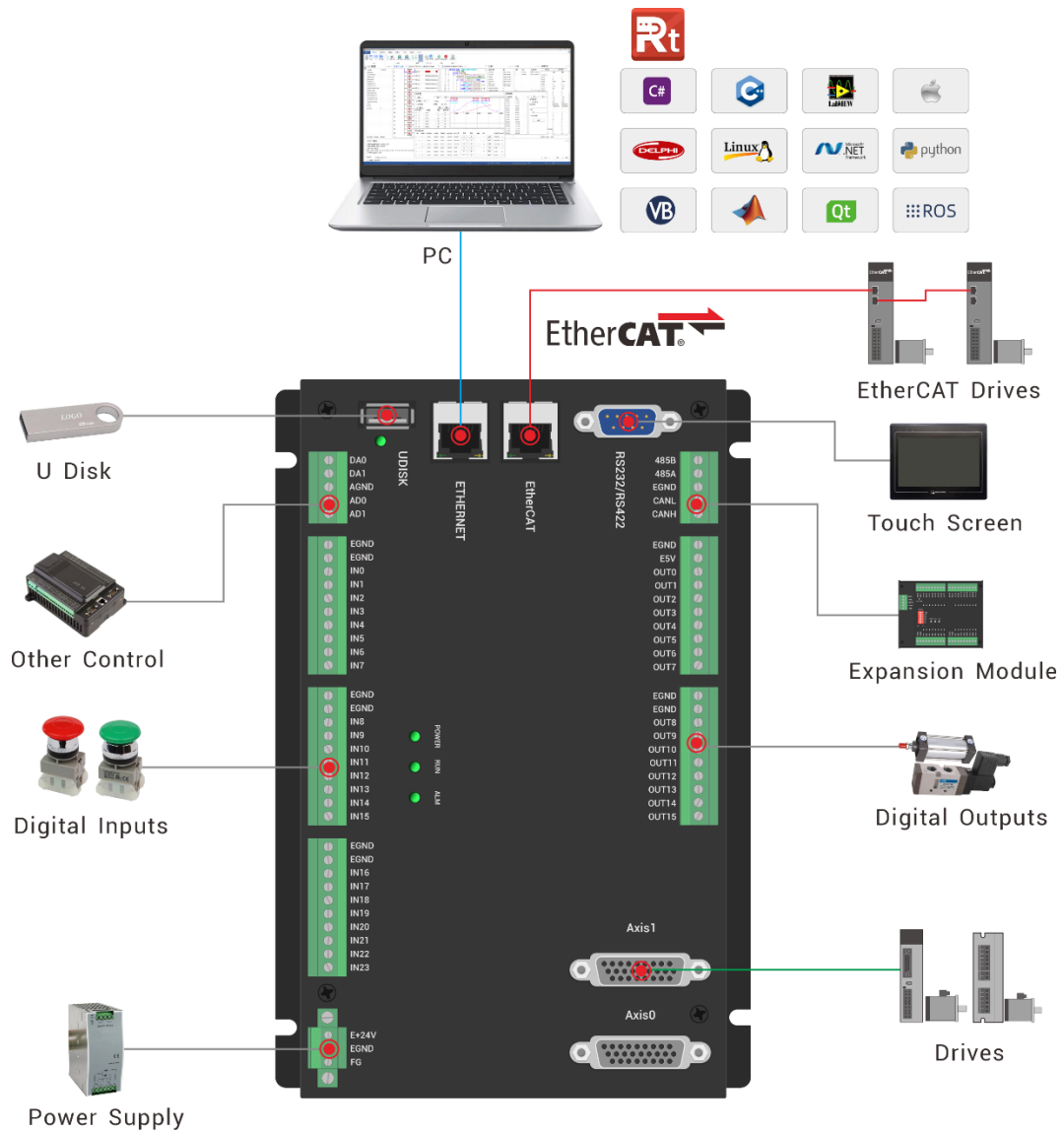

1.4. Hardware Installation

The ZMC308E motion controller adopts the horizontal installation method of screw fixing, and each controller should be installed with 4 screws for fastening.

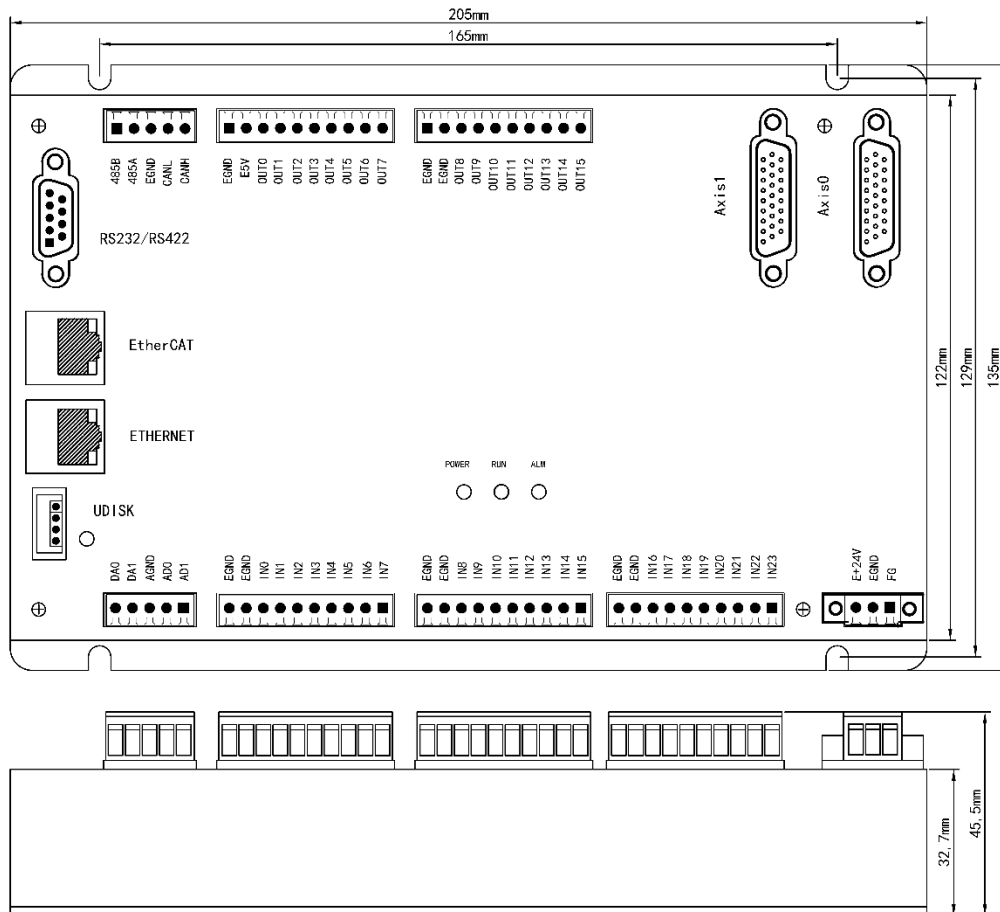

→ Unit: mm → Installment Hole Diameter: 4.5mm



Installation attention

- Non-professionals are strictly prohibited to operate. Specifically, professionals who had been trained related electrical equipment, or who master electrical knowledge.
- Please be sure to read the product instruction manual and safety precautions carefully before installation.
- Before installation, please ensure that the product is powered off.
- Do not disassemble the module, otherwise the machine may be damaged.
- Avoid direct sunlight installation.
- In order to facilitate ventilation and controller replacement, 2-3cm should be left between the upper and lower parts of the controller and the installation environment and surrounding components.
- Considering the convenient operation and maintenance of the controller, please **do not** install the controller in the following places:

	<ul style="list-style-type: none">a) places where the surrounding ambient temperature exceeds the range of -10°C-55°Cb) places where the ambient humidity exceeds the range of 10%-95% (non-condensing)c) places with corrosive gases and flammable gasesd) places with many conductive powders such as dust and iron powder, oil mist, salt, and organic solvents
--	---

Chapter II Product Specification

2.1. Basic Specification

Item	Description		
Model	ZMC308E	ZMC306E	ZMC304E
Basic Axes	8	6	4
Max Extended Axes	12		
Basic Axes Type	EtherCAT bus axes / pulse axes / encoder axes		
Digital IO	General IOs: 24 inputs and 16 outputs Axis interface IO: 1 IN and 1 OUT of each pulse axis		
Max Extended IO	4096 inputs and 4096 outputs		
PWM	4		
AD/DA	2 general ADs, 0-10V. 2 general DAs, 0-10V.		
Max Extended AD/DA	512 ADs, 512 DAs		
Pulse Bit	32		
Encoder Bit	32		
Speed Acceleration Bit	32		
Pulse Max Frequency	10MHz		
Motion Axis Buffer	512		
Array Space	320000		
Program Space	6144KByte		
Flash Space	128MByte		
Power Supply Input	24V DC input		
Communication Interfaces	RS232, RS485, Ethernet, U disk, CAN, EtherCAT		
Dimensions	205mm*135mm*33mm		

2.2. Model Selection

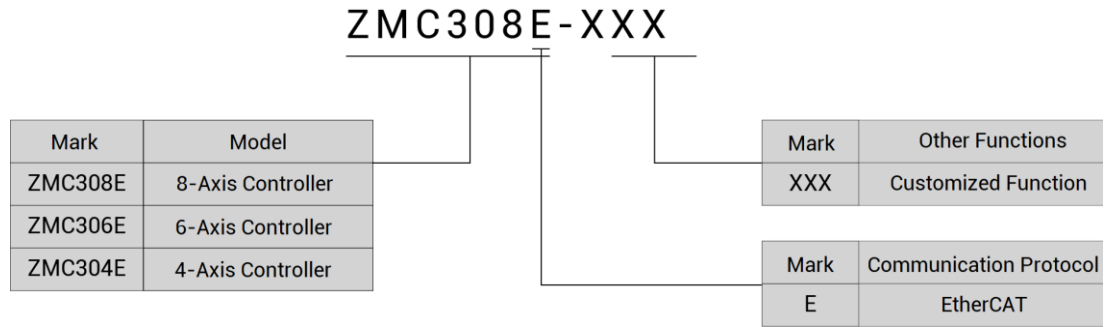

Model	Description
ZMC308E	8 axes, point to point, linear, circular, electronic cam, continuous trajectory motion, robotic arm instructions.
ZMC306E	6 axes, point to point, linear, circular, electronic cam, continuous trajectory motion, robotic arm instructions.
ZMC304E	4 axes, point to point, linear, circular, electronic cam, continuous trajectory motion, robotic arm instructions.

2.3. Interface Definition

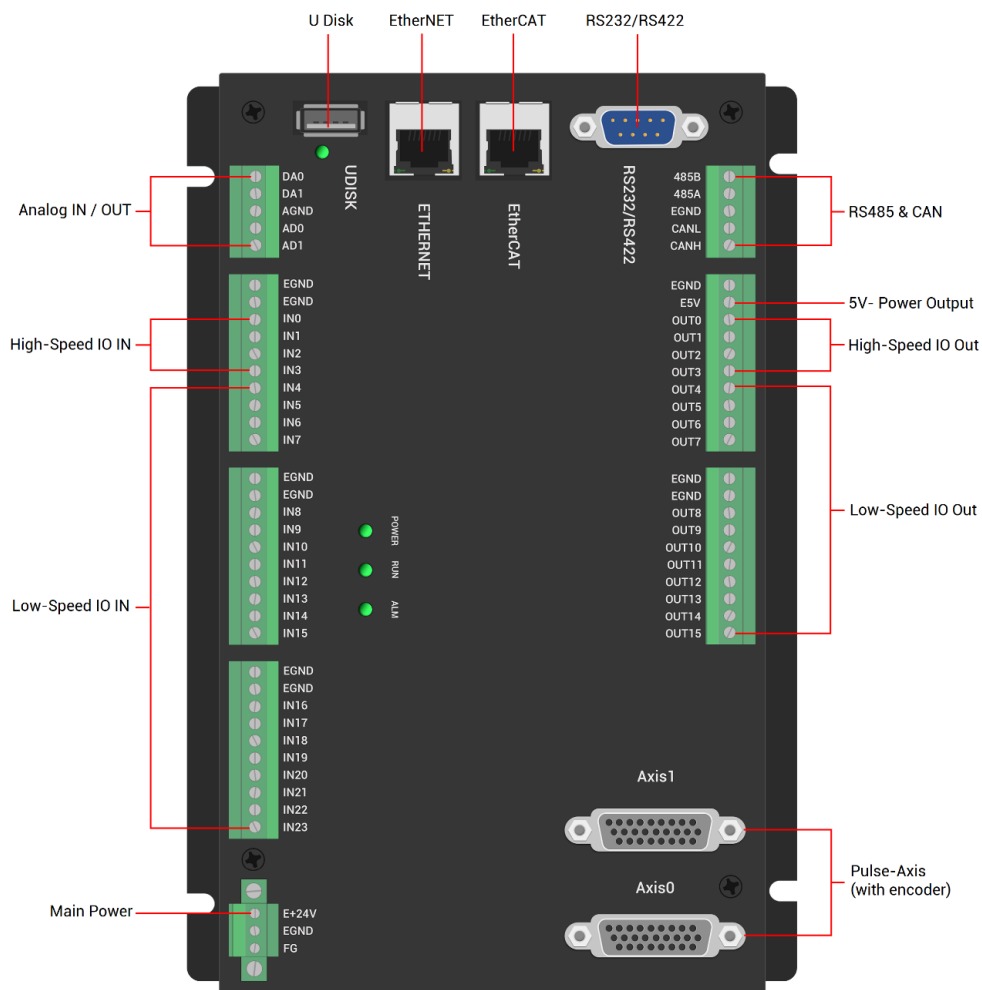

→ Interface Description

Mark	Interface	Number	Description
POWER	Status Indication Light	1	Power indicator: it lights when power is conducted.
RUN		1	Run indicator: it lights when runs normally
ALM		1	Error indicator: it lights when runs abnormally
RS232	RS232 serial port (port0)	1	Use MODBUS_RTU protocol
RS485	RS485 serial port (port1)	1	Use MODBUS_RTU protocol
RS422	RS422 serial port (port2)	1	Use MODBUS_RTU protocol
EtherCAT	EtherCAT bus interface	1	EtherCAT bus interface, connect to EtherCAT bus drive and EtherCAT bus expansion module

ETHERNET	Ethernet	1	Use MODBUS_TCP protocol, expand Ethernet through interchanger, the number of net port channels can be checked through "?*port", default IP address id 192.168.0.11
UDISK	U disk	1	Insert U disk equipment
E+24V	Main power	1	24V DC power supplies for controller
CAN	CAN bus	1	Connect to CAN expansion module or controller.
IN	Digital IO input	24	NPN type, internal 24V supply power, 4 high-speed inputs, IN0-3 have latch function.
OUT	Digital IO output	12	NPN type, 4 high-speed outputs, OUT0-3 support PWM and hardware comparison output function.
AD	Analog input	2	Resolution: 12 bits, 0-10V
DA	Analog output	2	Resolution: 12 bits, 0-10V
AXIS	Pulse axis	2	Each interface includes differential pulse output and differential encoder input

2.4. Work Environment

Item		Parameters
Work Temperature		-10°C-55°C
Work relative Humidity		10%-95% non-condensing
Storage Temperature		-40°C ~ 80°C (not frozen)
Storage Humidity		Below 90%RH (no frost)
vibration	Frequency	5-150Hz
	Displacement	3.5mm(directly install)(<9Hz)
	Acceleration	1g(directly install)(>9Hz)
	Direction	3 axial direction
Shock (collide)		15g, 11ms, half sinusoid, 3 axial direction
Degree of Protection		IP20

Chapter III Wiring & Communication

3.1. Power Input

The power input adopts a screw-type pluggable terminal with a 3Pin pitch of 3.81mm, which is the power supply of the controller.

→ Terminal Definition:

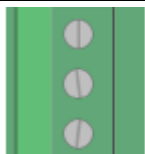
Terminal	Name	Type	Function
	E+24V	Input	Positive of DC input
	EGND	Input	Negative of DC input
	FG	Connect to ground	Case Protection Ground

3.1.1. Power Specification

→ Specification

Item	Description
Input Voltage	DC24V (-5%~5%)
Opening Current	≤0.5A
Work Current	≤0.4A
Anti-reverse connection	YES
Overcurrent Protection	YES

3.2. RS485, CAN Communication Interface

The communication interface adopts a screw-type pluggable wiring terminal with a 5Pin spacing of 3.81mm. RS485 communication and CAN communication can be connected to corresponding terminals to use through this terminal.

→ Terminal Definition:

Terminal	Name	Function
485B	485B	485-
485A	485A	485+
EGND	EGND	Communication public end
CANL	CANL	CAN differential data -
CANH	CANH	CAN differential data +

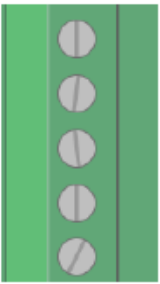

3.2.1. RS485, CAN Communication Specification & Wiring

The RS485 serial port supports the MODBUS_RTU protocol and custom communication, mainly including 485A, 485B and public end.

The CAN interface of the controller adopts the standard CAN communication protocol, which mainly includes three ports, CANL, CANH and the public end. And it supports connecting CAN expansion modules and other standard CAN devices.

→ Specification

Item	RS485 (port1)	CAN
Max Communication Rate	115200(bps)	1M(bps)
Terminal Resistor	/	120Ω
Topology	Daisy chain connection structure	
Nodes can be extended	Up to 127	Up to 16
Communication Distance	Longer communication distance, lower communication rate, max 30m is recommended.	

→ Wiring Reference

Connect 485A and 485B of RS485 to 485A and 485B of the controller correspondingly, and connect the public end of both parties of RS485 communication together.

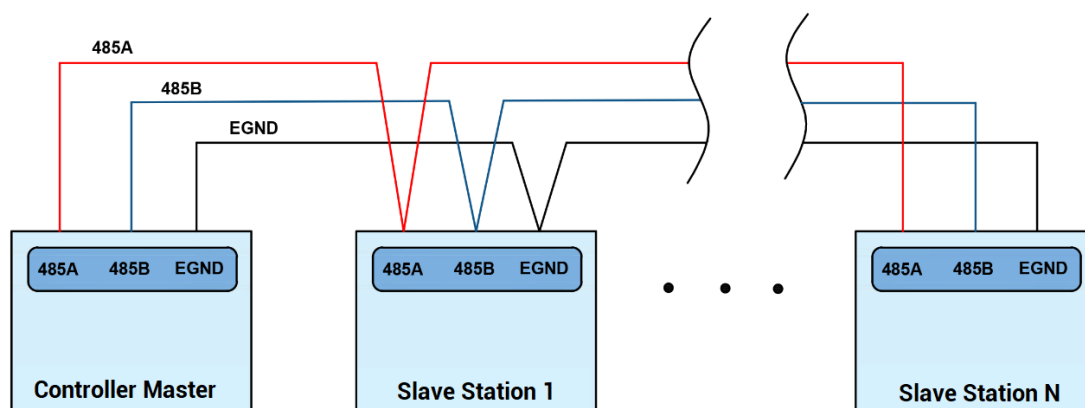

Connect the CANL and CANH of the standard CAN module to the CANL and CANH of the other side correspondingly. And public ends of the CAN bus communication both parties are connected together. In CAN bus left and right sides, connect a 120Ω resistor respectively (please see below graphic).

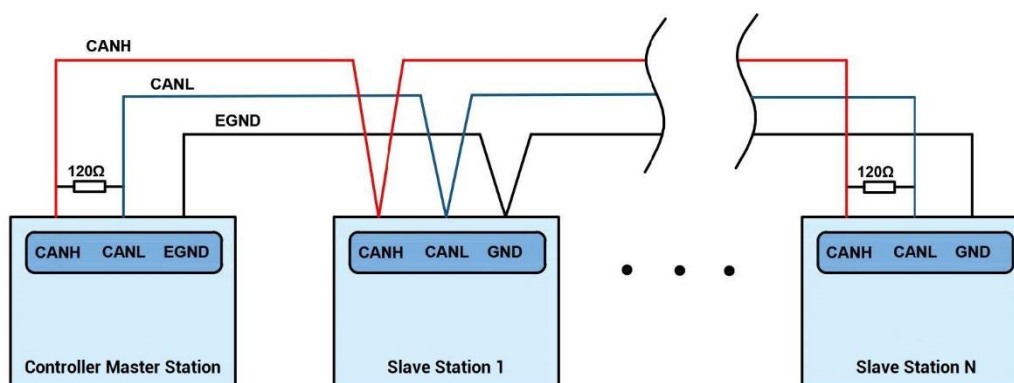

→ Wiring Notes:

- As above, the daisy chain topology is used for wiring, so the star topology cannot be used. When the use environment is ideal and there are few nodes, the branch structure can also be considered.
- Please connect a 120Ω terminal resistor in parallel at the two ends of the CAN bus / RS485 to match the circuit impedance and ensure communication stability.
- Please be sure to connect the common terminal of each node on the CAN bus / RS485 to prevent the CAN chip from burning out.
- Please use twisted-pair shielded wires, especially in harsh environments, make sure

the shielding layer is fully grounded.

- On-site wiring should also pay attention to the distance between strong current and weak current wiring, it is recommended to be more than 20cm.
- It should be noted that the equipment grounding (chassis) on the entire line must be good, and the grounding of the chassis should be connected to the standard factory ground pile.

→ Cable Requirements:

Twisted pair shielded wire, and shielded cable grounded.

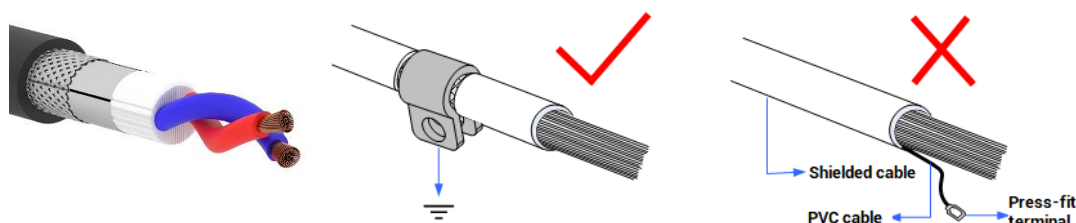

3.2.2. Basic Usage Method

- (1) Please follow the above wiring instructions for correct wiring.
- (2) After power on, please use ETHERNET or RS232 or RS485 to connect to [RTSys](#).
- (3) Please use the "ADDRESS" and "SETCOM" commands to set and view the protocol station number and configuration parameters, see "Basic Programming Manual" for details.
- (4) Please use the "CANIO_ADDRESS" command to set the master's "address" and "speed" according to the needs, and use the "CANIO_ENABLE" command to enable or disable the internal CAN master function, or through "RTSys/Controller/State the Controller/Communication Info" to view the CAN status intuitively, and refer to the "Basic Programming Manual" for details.

```
CAN communication settings:
CANIO_ADDRESS = 32, CANIO_ENABLE = 1
ZCAN Master
CAN baud: 500KBPS
CAN enable: ON
|
Serial port configuration:
Port0:(RS232) is ModbusSlave Mode.
Address: 1, variable:2
Baud:38400
DataBits:8
StopBits: 1
Parity:0
Port1:(RS485) is ModbusSlave Mode.
Address: 1, variable:2
Baud:38400
DataBits:8
StopBits: 1
Parity:0
Port2:(RS422) is ModbusSlave Mode.
Address: 1, variable:2
Baud:38400
DataBits:8
```

- (5) Correctly set the relevant parameters of the third-party equipment according to their respective instructions to match the parameters of each node.
- (6) Correctly set the "address" and "speed" of the slave expansion module according to the manual of the slave.
- (7) After all the settings are completed, restart the power supply of all stations to establish communication.
- (8) Note that the "speed" settings of each node on the CAN bus must be consistent, and the "address" settings cannot cause conflicts, otherwise the "ALM" alarm light will be on, and the communication establishment will fail or the communication will be disordered.

3.3. RS232, RS422 Serial Ports

RS232 and RS422 are in a standard DB9 socket and support MODBUS_RTU protocol and custom communication.

→ **Interface Definition:**

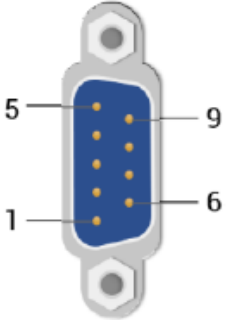
Terminal	PIN	Name	Type	Function
	1	422TX+	Output	RS422, send signal +
	2	232RXD	Input	RS232, receive signal
	3	232TXD	Output	RS232, send signal
	4	422RX+	Input	RS422, receive signal +
	5	EGND	Output	Negative pole of 5V power supply outputs, the public end of this communication
	6	422TX-	Output	RS422, send signal -
	7	422RX-	Input	RS422, receive signal -
	9	E5V	Output	Positive pole of 5V power output, max is 300mA

3.3.1. RS232, RS422 Specification & Wiring

→ **Specification:**

Item	RS232 (port 0)	RS422 (port 2)
Max Communication Rate	115200(bps)	115200(bps)
Terminal Resistor	No	No
Topology	Connect correspondingly (point to point)	Point to multi-point connection
Nodes can be extended	1	Up to 10
Communication Distance	Longer communication distance, lower communication rate, max 5m is recommended.	Longer communication distance, lower communication rate, max 30m is recommended.

→ **Wiring Reference:**

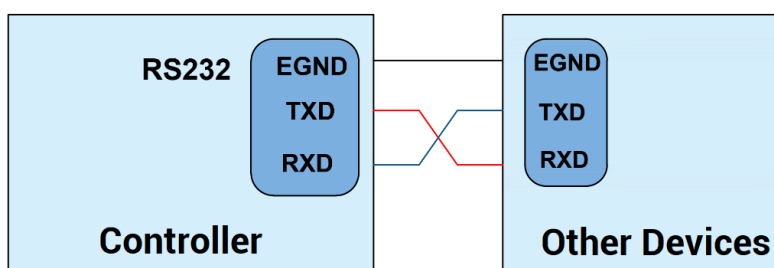

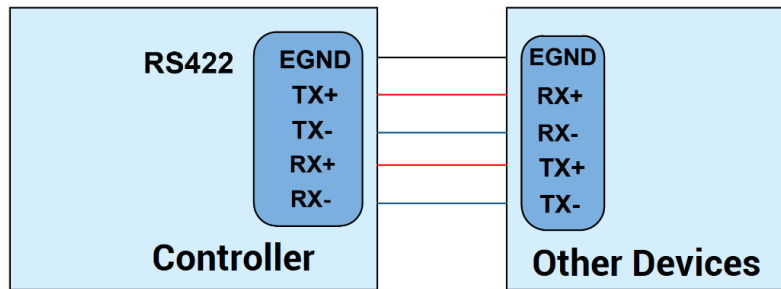

→ Wiring Notes:

- The wiring of RS232 is as above, the sending and receiving signals need to be cross-connected, and it is recommended to use a double-female cross line when connecting to a computer.
- Please be sure to connect the common terminal of each communication node to prevent the communication chip from burning out.
- Please use twisted-pair shielded cables, especially in harsh environments, and make sure the shielding layer is fully grounded.

→ Cable Requirements:

Twisted pair shielded wire, and shielded cable grounded.

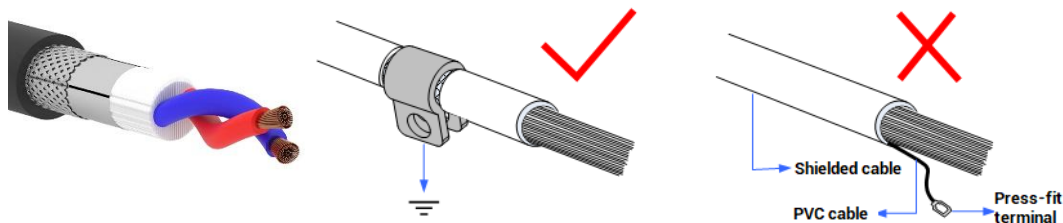

3.3.2. Basic Usage Method

- (1) Please follow the above wiring instructions for correct wiring.
- (2) After power on, please use ETHERNET or RS232/RS422 (default parameter, it can be connected directly) or RS485 (default parameter, it can be connected directly, adapter head needs to be used) to connect to [RTSys](#).

- (3) Please use the "ADDRESS" and "SETCOM" commands to set and view the protocol station number and configuration parameters, see "Basic Programming Manual" for details.
- (4) Correctly set the relevant parameters of the third-party equipment according to their respective instructions to match the parameters of each node.
- (5) When all is configured, it can start to do communicating.
- (6) Communication data of RS232/RS485 can be directly viewed through "RTSys / Controller / State the Controller / CommunicationInfo".

```
CAN communication settings:
CANIO_ADDRESS = 32, CANIO_ENABLE = 1
ZCAN Master
CAN baud: 500KBPS
CAN enable: ON
|
Serial port configuration:
Port0:(RS232) is ModbusSlave Mode.
Address: 1, variable:2
Baud:38400
DataBits:8
StopBits:1
Parity:0
Port1:(RS485) is ModbusSlave Mode.
Address: 1, variable:2
Baud:38400
DataBits:8
StopBits:1
Parity:0
Port2:(RS422) is ModbusSlave Mode.
Address: 1, variable:2
Baud:38400
DataBits:8
```

3.4. IN Digital Input & High-Speed Latch & Single-ended Encoder

The digital input adopts 3 groups of 10Pin screw-type pluggable terminals with a pitch of 3.81mm, and the high-speed latch function and single-ended encoder function are integrated.

→ Wiring Definition

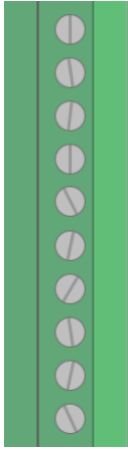
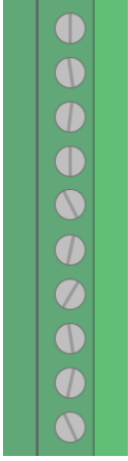
Terminal	Name	Type	Function 1	Function 2	Function 3
 EGND EGND IN0 IN1 IN2 IN3 IN4 IN5 IN6 IN7	EGND	/	IO public	/	/
	EGND	/	end	/	/
	IN0	NPN, high-speed input	Input 0	High-speed latch	EA2
	IN1		Input 1		EB2
	IN2		Input 2		EZ2
	IN3		Input 3		/
	IN4	NPN, low-speed input	Input 4	/	/
	IN5		Input 5	/	/
	IN6		Input 6	/	/
	IN7		Input 7	/	/
 EGND EGND IN8 IN9 IN10 IN11 IN12 IN13 IN14 IN15	EGND	/	IO public	/	/
	EGND	/	end	/	/
	IN8	NPN, low-speed input	Input 8	/	/
	IN9		Input 9	/	/
	IN10		Input 10	/	/
	IN11		Input 11	/	/
	IN12		Input 12	/	/
	IN13		Input 13	/	/
	IN14		Input 14	/	/
	IN15		Input 15	/	/
 EGND EGND IN16 IN17 IN18 IN19 IN20 IN21 IN22 IN23	EGND	/	IO public	/	/
	EGND	/	end	/	/
	IN16	NPN, low-speed input	Input 16	/	/
	IN17		Input 17	/	/
	IN18		Input 18	/	/
	IN19		Input 19	/	/
	IN20		Input 20	/	/
	IN21		Input 21	/	EZ3
	IN22		Input 22	/	EB3
	IN23		Input 23	/	EA3
Note:					

- ◇ IN0-3 support 24V high-speed latch function.
- ◇ IN0-2 support 24V high-speed encoder function, IN21-23 support 24V low-speed encoder function. When ATYPE=0, they are ordinary inputs.

3.4.1. Digital Input Specification & Wiring

→ Specification

Item	High-Speed Input (IN0-3)	Low-Speed Input (IN4-23)
Input mode	NPN type, trigger by low electric level	
Input frequency	< 100kHz	< 5kHz
Input impedance	3.3KΩ	4.7KΩ
Input voltage level	DC24V	DC24V
Voltage to ON	<15V	<14.5V
Voltage to OFF	>15.1V	>14.7V
Min input current	-2.3mA	-1.8mA
Max input current	-7.5mA	-6mA
Isolation mode	Photoelectric isolation	Photoelectric isolation

Note: the above parameters are standard values when the controller power supply voltage (E+24V port) is 24V.

→ Wiring Reference

--General IN Wiring--

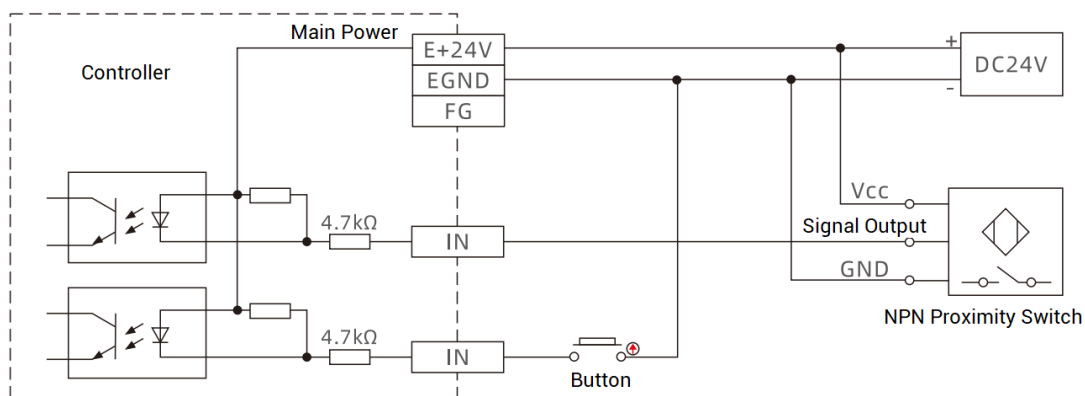

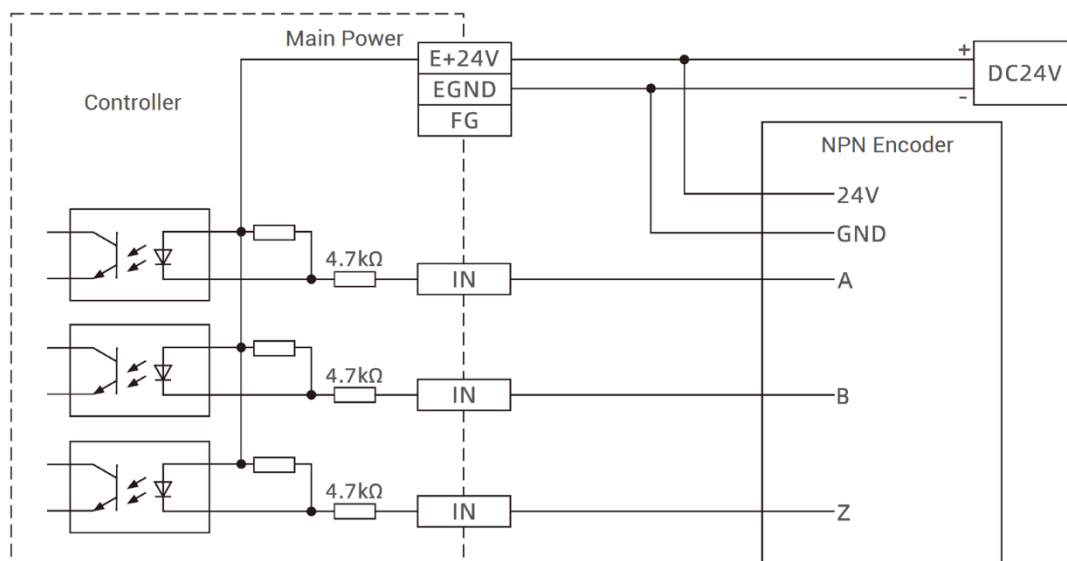
--Single-Ended Encoder IN Wiring--**→ Wiring Note:**

- The wiring principle of high-speed digital input IN (0-3) and low-speed digital input IN (4-23) is shown in the figure above. The external signal source can be optocoupler or key switch or sensor, etc., as long as the output level meets the requirements, it can be connected.
- For the common terminal, please select the "EGND" port on the IO power supply terminal to connect to the "COM" terminal of the external input device. If the power supply of the signal area of the external device and the power supply of the controller are in the same power supply system, this connection can also be omitted.

3.4.2. Basic Usage Method

- (1) Please follow the above wiring instructions for correct wiring.
- (2) After power on, please use any of the three interfaces ETHERNET, RS232 and RS485 to connect to [RTSys](#).
- (3) State values of relative inputs can be read directly through "IN" command, also, it can be read through "RTSys/Tool/In". Please refer to "Basic" for details.

- (4) Latch function can be set and opened through "REGIST" instruction, in software, use REG_INPUTS to configure. Please refer to "Basic" for details.

3.5. OUT Digital Output, PWM Terminal, Hardware Comparison Output, Single-ended Pulse

The digital output adopts 2 sets of screw-type pluggable terminals with a spacing of 3.81mm, and the digital output signal is integrated with PWM, hardware comparison output and single-ended pulse functions.

→ **Wiring Definition**

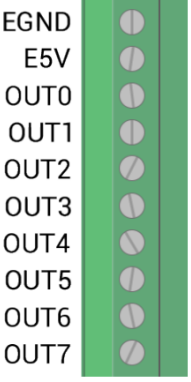
Terminal	Name	Type	Function 1	Function 2	Function 3	Function 4
	EGND	/	E5V power ground / IO Public End	/	/	/
	E5V	/	5V power out, max 300mA	/	/	/
	OUT0	NPN, high-speed output	Output 0	PWM out 0	Hardware comparison output	PUL2
	OUT1		Output 1	PWM out 1		DIR2
	OUT2		Output 2	PWM out 2		PUL3
	OUT3		Output 3	PWM out 3		DIR3
	OUT4	NPN, low-speed output	Output 4	/	/	/
	OUT5		Output 5	/	/	/
	OUT6		Output 6	/	/	/
	OUT7		Output 7	/	/	/
	EGND	/	IO public end	/	/	/
	EGND	/		/	/	/
	OUT8	NPN, low-speed output	Output 8	/	/	/
	OUT9		Output 9	/	/	/
OUT10	Output 10		/	/	/	

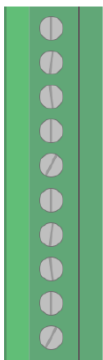
EGND		OUT11	Output 11	/	/	/
EGND		OUT12	Output 12	/	/	/
OUT8		OUT13	Output 13	/	/	/
OUT9		OUT14	Output 14	/	/	/
OUT10		OUT15	Output 15	/	/	/
OUT11						
OUT12						
OUT13						
OUT14						
OUT15						

Notes:

- ◇ The E5V power output port is used for PWM or single-ended axis common anode wiring, and it is not recommended for other purposes because of low power.
- ◇ OUT0-3 support the functions of PWM and hardware comparison output.
- ◇ OUT0-3 support the function of single-ended pulse, when ATYPE=0, they are ordinary output ports.
- ◇ The maximum output current of OUT0-1 is 500mA, and the maximum output current of OUT3-15 is 300mA.

3.5.1. Digital Output Specification & Wiring

→ Specification

Item	High Speed (OUT0-3)	Low Speed (OUT4-11)
Output mode	NPN type, 0V when outputs	
Output frequency	< 400kHz	< 8kHz
Output voltage level	DC24V	DC24V
Max output current	+300mA (OUT0-1 are 500mA)	+300mA
Max leakage current when OFF	25μA	25μA
Conduction respond time	1μs (resistive load typical value)	12μs
Respond time when OFF	3μs	80μs
Overcurrent protection	Support	Support
Isolation method	Photoelectric isolation	

Note:

- ✧ The times in the table are typical based on the resistive load, and may change when the load circuit changes.
- ✧ Due to the leak-type output, the shutdown of the output will be more obviously affected by the external load circuit, and the output frequency should not be set too high in the application.

→ **Wiring Reference**

--General OUT Wiring--

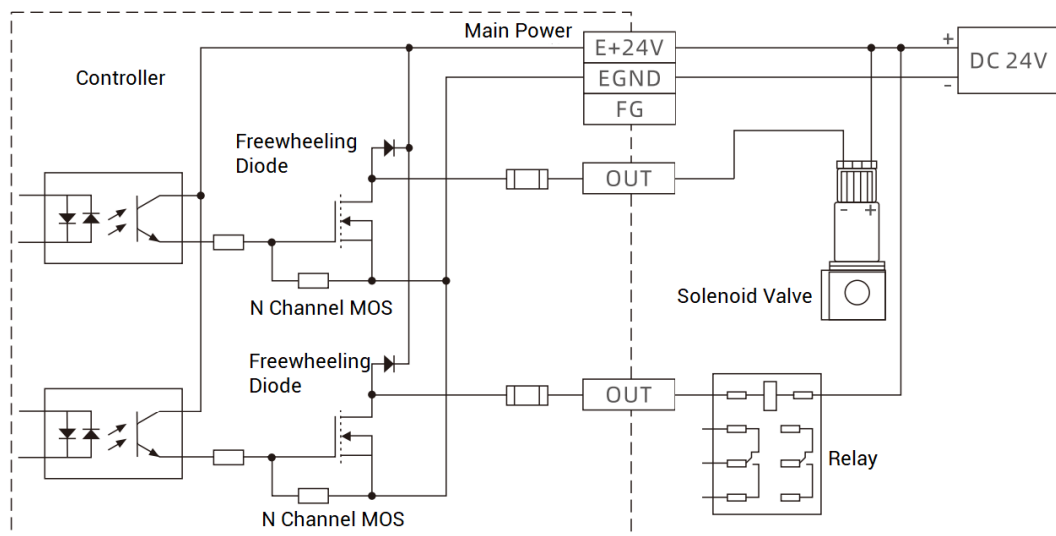

--Pulse Axis Wiring--

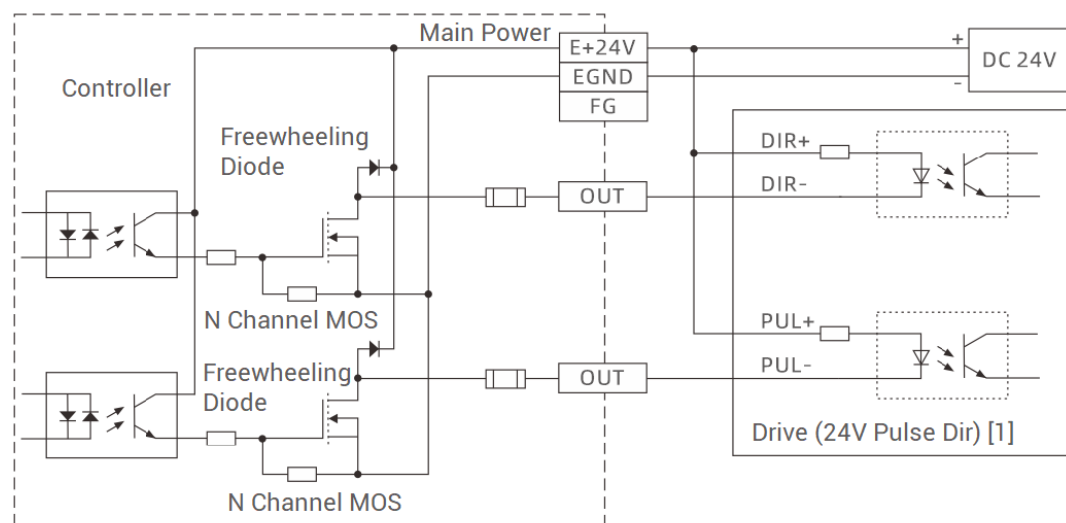

Note [1]: for 5V pulse directional interface, please connect PUL+ and DIR+ to E5V.

→ Wiring Note:

- The wiring principle of high-speed digital output OUT (0-3) and low-speed digital output OUT (4-11) is shown in the figure above. The external signal receiving end can be an optocoupler or a relay or solenoid valve, as long as the input current does not exceed 300mA.
- For the connection of the common terminal, please select the "EGND" port on the IO terminal to connect to the negative pole of the DC power supply of the external input device. If the DC power supply of the external device and the controller power supply are in the same power supply system, this connection can also be omitted.
- The E5V port is a 5V power output port, which can be used when facing some loads that need to provide an external 5V power input, with a maximum current of 500mA.

3.5.2. Basic Usage Method

- (1) Please follow the above wiring instructions for correct wiring.
- (2) After power on, please use any of the three interfaces ETHERNET, RS232 and RS485 to connect to [RTSys](#).
- (3) Terminal can be operated to ON or OFF directly through "OP" command, also, it can be opened or closed through "RTSys/Tool/Op". Please refer to "Basic" for details.
- (4) PWM function can be used to set frequency and duty cycle through "PWM_FREQ" and "PWM_DUTY". Please refer to Basic for details.
- (5) Hardware comparison output can be set and opened through "HW_PSWITCH2". Please refer to Basic for details.

3.6. AD/DA Analog Input & Output

ZMC308E provides one set of screw-type pluggable wiring terminal with a spacing of 3.81mm.

→ **Wiring Definition**

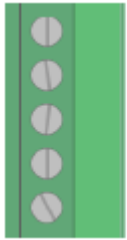
Interface	Name	Type	Description
	DA0	Output	Analog output terminal AOUT(0)
	DA1	Output	Analog output terminal AOUT(1)
	AGND	Public end	Analog public end
	AD0	Input	Analog input terminal AIN(0)
	AD1	Input	Analog input terminal AIN(1)

3.6.1. Analog Input / Output Specification & Wiring

→ **Specification**

Item	AD (0-1)	DA (0-1)
Resolution	12-bit	12-bit
Data range	0-4095	0-4095
Signal range	0-10V input	0-10V output
Data refresh ratio	1KHz	1KHz
Voltage input impedance / output load	300KΩ (voltage input impedance)	>33KΩ (voltage output load)

→ **Wiring Reference**

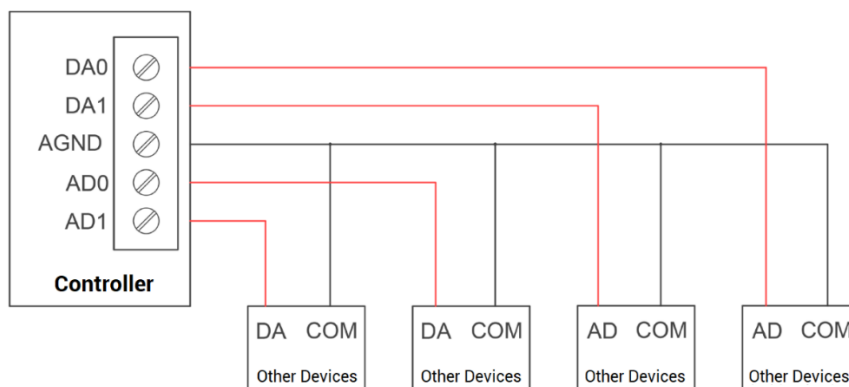

→ **Wiring Note:**

- The analog input/output wiring method is as shown in the figure above, and the external load signal range must match it.

- Please use twisted-pair shielded cables, especially in harsh environments, and make sure the shielding layer is fully grounded.

→ Cable Requirements:

- Twisted pair shielded wire, and shielded cable grounded.

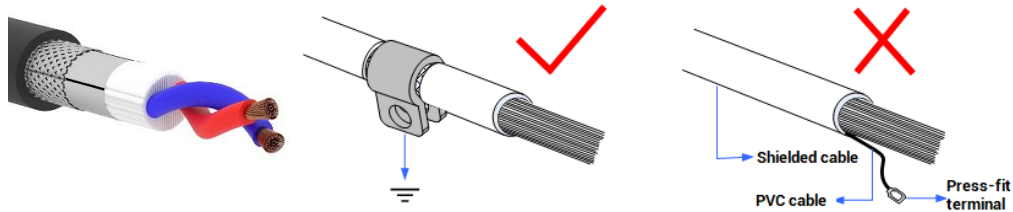

3.6.2. Basic Usage Method

- (1) Please follow the above wiring instructions for correct wiring.
- (2) After power on, please use any of the three interfaces ETHERNET, RS232 and RS485 to connect to RTSys.
- (3) Analog input voltage can be read through "AIN" command and corresponding analog voltage can be output through "AOUT" command, also, data of each channel can be checked through "RTSys/View/AD/DA". Please refer to "Basic" for details.

AD/DA					
控制器类型: ZMC308E					重新读取
AD:					
通道号	大小	刻度值	电压或电流值	最大刻度值	电压或电流范围
0	0%	0	0.000	4095	0~10V
1	0%	0	0.000	4095	0~10V
DA:					
通道号	大小	刻度值	电压或电流值	最大刻度值	电压或电流范围
0	0%	0	0.000	4095	0~10V
1	0%	0	0.000	4095	0~10V

3.7. U Disk

The ZMC308E motion controller provides a USB communication interface to insert a U disk device, which is used for ZAR program upgrade, controller data import and export, and 3 file executions. Its schematic diagram is shown in the figure below:

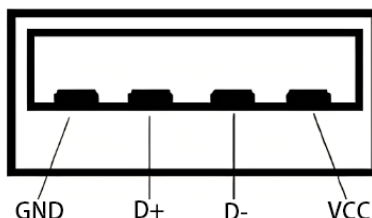

→ **Specification**

Item	USB2.0
Max Communication Ratio	12Mbps
Max Output Current of 5V	500mA
Whether Isolates	No

3.8. ETHERNET

ZMC308E motion controller has an 100M Ethernet port, supports MODBUS_TCP protocol and custom communication, and the default IP address is 192.168.0.11. The pin definition diagram is as follows:

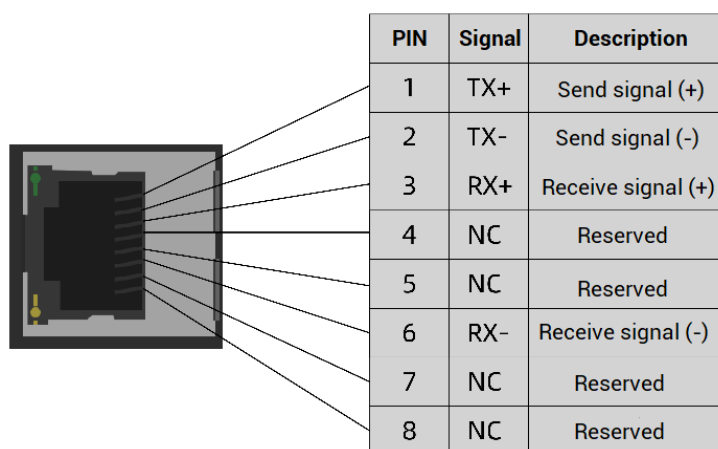

The Ethernet port of the controller can be connected point-to-point with a computer, HMI, etc. through an Ethernet cable. The schematic diagram is as follows:

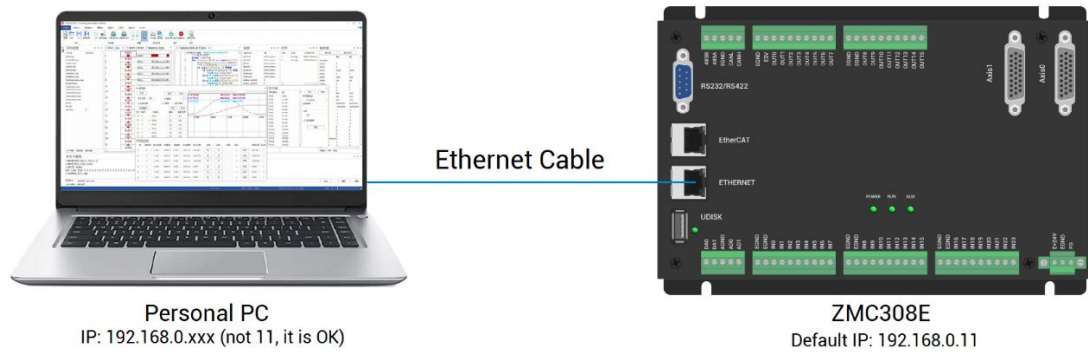

The controller can also be connected to the interchanger through an Ethernet cable, and connected to other devices through the interchanger to realize multi-point connection. The schematic diagram is as follows:

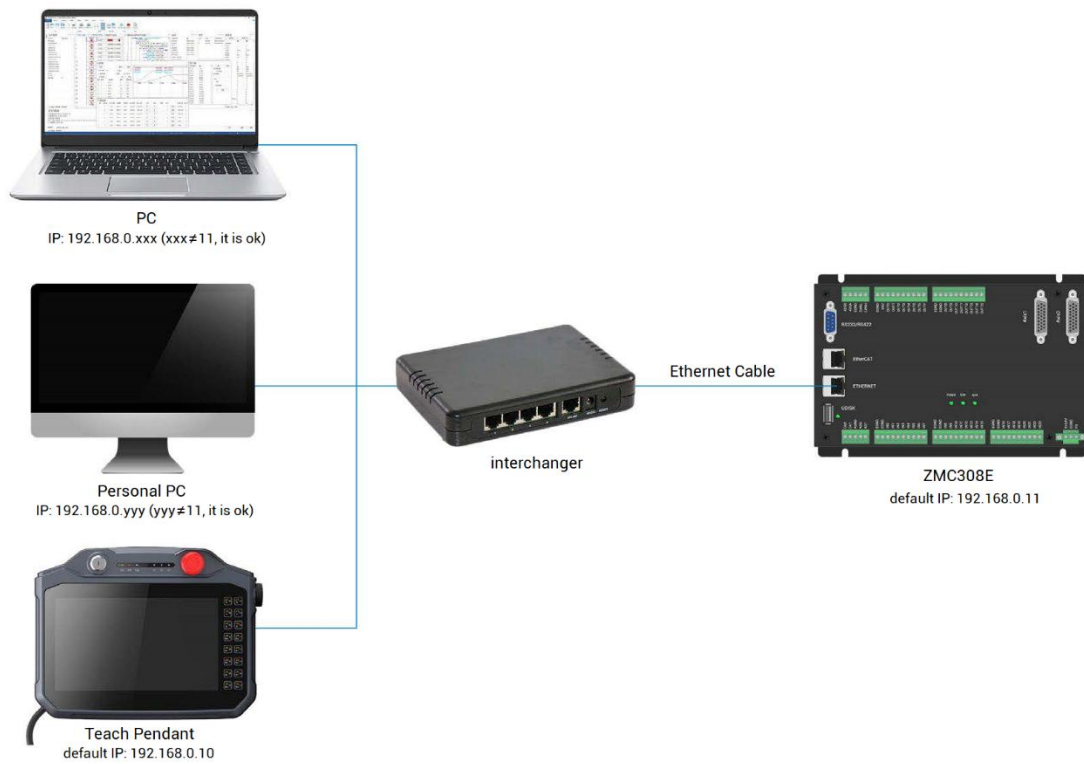

3.9. EtherCAT Bus Interface

ZMC308E motion controller has a 100M EtherCAT communication interface, supports EtherCAT protocol, and connects to EtherCAT driver or EtherCAT expansion module. The pin definition diagram is as follows:

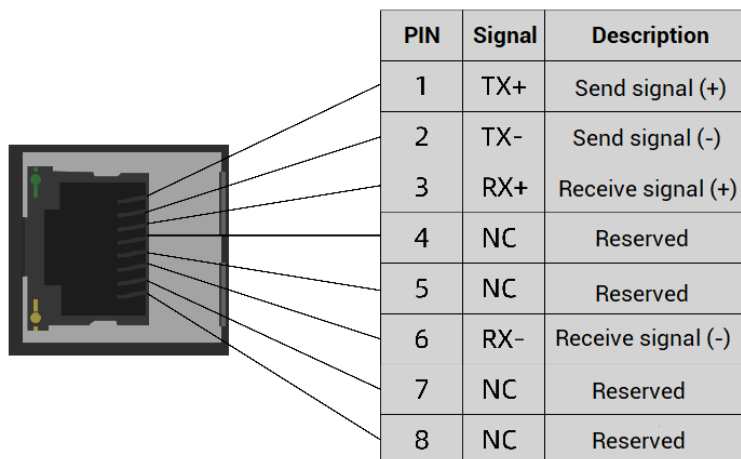

→ Specification

Item	Specification
Communication protocol	EtherCAT protocol
Valid service	CoE (PDO、SDO)、FoE
Synchronization method	IO adopts input and output synchronization / DC-distributed clock
Physical level	100BASE-TX
Duplex mode	full duplex
Topology	linear topology
Transfer media	Cable
Transfer distance	It is less than 100m between 2 nodes
Process data	Max 1486 bytes of single frame
Synchronization shaking of two slave stations	<1us
Refresh	1000 digital input and output about 30us

→ Communication Cable Requirements

Both ETHERNET communication interface and EtherCAT communication interface adopt standard Ethernet RJ45 interface.

The network cable adopts Category 5e shielded twisted pair, and the crystal head has a metal shell to reduce interference and prevent information from being eavesdropped.

As shown below:

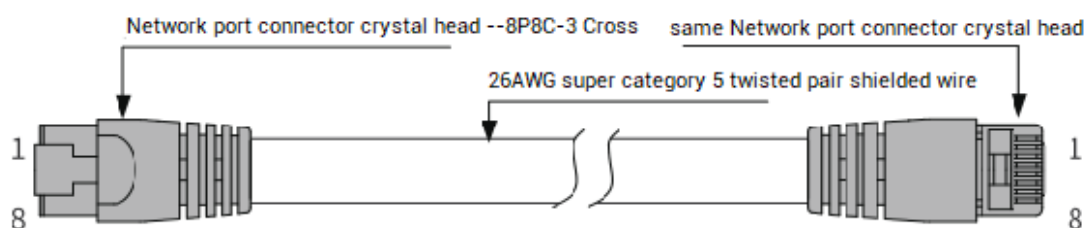

Item	Specification
Cable type	Flexible crossover cable, Cat 5e
Cable type	twisted pair
Cable pair	4
Isolation	cross skeleton
Connector	Crystal head with iron shell
Cable material	PVC
Cable length	Less than 100m

Use RJ45 network cable connection method:

- When installing, hold the crystal head with the cable and insert it into the RJ45 interface until it makes a "click" sound (kada).
- In order to ensure the stability of communication, please fix the cables with cable ties.
- When disassembling, press the tail mechanism of the crystal head and pull out the connector and the module in a horizontal direction.

Please use tube-type pre-insulated terminals and cables with appropriate wire diameters to connect the user terminals.

3.10. AXIS Differential Pulse Axis Interface

This product provides 2 local differential pulse axis interfaces, each interface is a standard DB26 female socket. Each terminal provides 0V and +5V output, which can provide 5V power for the encoder.

Before the axis is used, the use mode of the axis must be configured through the ATYPE parameter.

→ Interface Definition

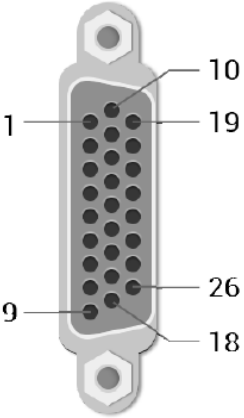
Interface	Pin	Signal	Description
	1	EGND	Digital IO power 24V negative pole
	2	IN24-25/ALM	Digital input, it is recommended to do drive alarm
	3	OUT16-17/ENABLE	Digital output, it is recommended to do drive enable
	4	EA-	Encoder differential input signal A-
	5	EB-	Encoder differential input signal B-
	6	EZ-	Encoder differential input signal Z-
	7	+5V	Pulse/encoder signal 5V power supply positive pole
	8	Reserved	Reserved
	9	DIR+	Servo or step direction output differential signal+
	10	GND	Pulse/encoder signal 5V power supply negative pole
	11	PUL-	Servo or step pulse output differential signal-
	12	Reserved	Reserved
	13	GND	Pulse/encoder signal 5V power supply negative pole
	14	OVCC	Digital IO power 24V positive pole
	15	Reserved	Reserved
	16	Reserved	Reserved
	17	EA+	Encoder differential input signal A+
	18	EB+	Encoder differential input signal B+
	19	EZ+	Encoder differential input signal Z+
	20	GND	Pulse/encoder signal 5V power supply negative pole
	21	GND	
	22	DIR-	Servo or step direction output differential signal-
	23	PUL+	Servo or step pulse output differential signal+

	24	GND	Pulse/encoder signal 5V power supply negative pole
	25	Reserved	Reserved
	26	Reserved	Reserved

Note:

- ◇ ALM and ENABLE are recommended to be used as axis IO due to their small drive capacity.
- ◇ OVCC, +5V is only used for communication between the controller and the servo driver, please do not use it as power supply for other places.

--Relation of Pulse Axis PIN No. & IO--

Pulse Axis No.	Corresponding IN (PIN 2)	Corresponding OUT (PIN 3)
AXIS 0	IN24	OUT16
AXIS 1	IN25	OUT17

3.10.1. AXIS Interface Signal Specification & Wiring**→ Specification:**

Signal	Item	Description
PUL/DIR	Signal type	Differential output signal
	Signal voltage range	0-5V
	Signal max frequency	10MHz
EA/EB/EZ	Signal type	Differential input signal
	Signal voltage range	0-5V
	Signal max frequency	5MHz
IN24-25	Input method	NPN type, low electric level input trigger
	Input frequency	<5kHz
	Input impedance	6.8KΩ
	Input voltage level	DC24V
	Voltage to ON	<10.5V
	Voltage to OFF	>10.7V
	Min input current	-1.8mA

	Max input current	-4mA
	Isolation	Optical isolation
OUT16-17	Output method	NPN type, 0V when outputs
	Output frequency	<8kHz
	Output voltage level	DC24V
	Max output current	+50mA
	Overcurrent protection	No
	Isolation	Optical isolation
+5V, GND	5V power max output current	50mA
OVCC, EGND	24V power max output current	50mA

→ **Wiring Reference:**

--Reference example of wiring with Panasonic A5/A6 servo driver--

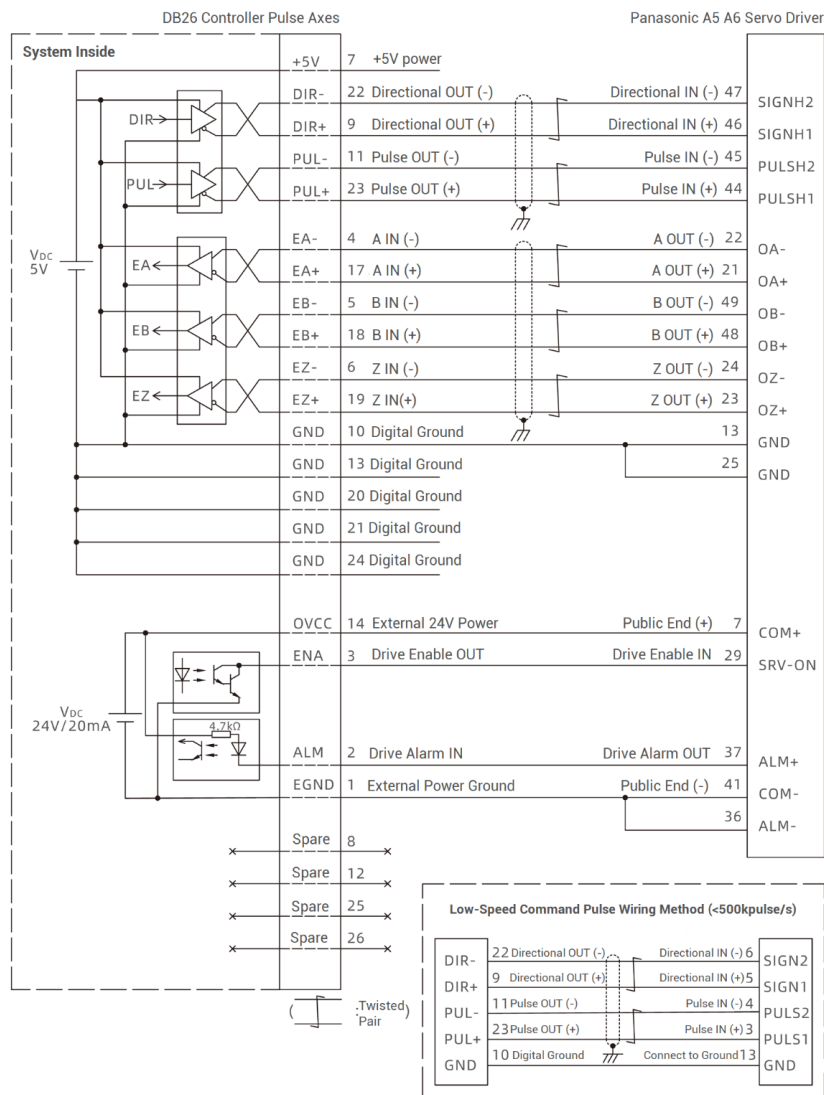

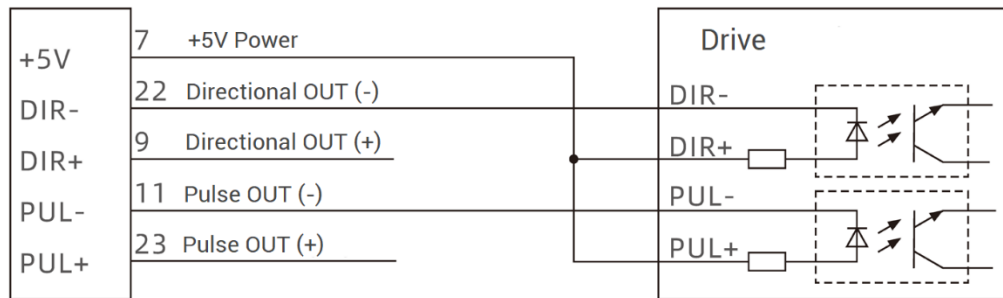
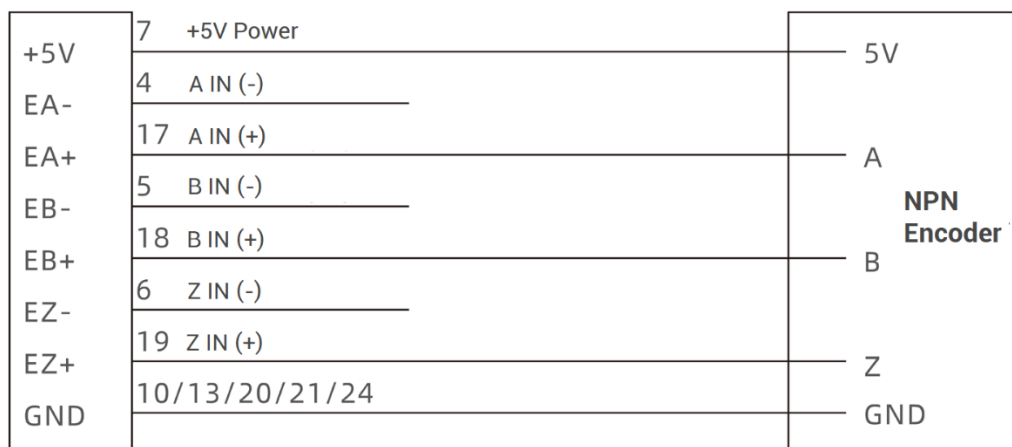
--Single-Ended Pulse Wiring--**--Single-Ended Encoder Wiring--****→ Wiring Note:**

- ✧ The wiring principle of the differential pulse axis interface is shown in the figure above, and the wiring methods of different types of drivers are different, please connect carefully.
- ✧ Please use twisted-pair shielded cables, especially in harsh environments, and make sure the shielding layer is fully grounded.

3.10.2. Basic Usage Method

- (1) Please follow the above wiring instructions for correct wiring.
- (2) After power on, please use any of the three interfaces ETHERNET, RS232 (default

parameter) and RS485 (default parameter, it can be connected directly) to connect to RTSys.

- (3) Set axis parameters, such as, ATYPE, UNITS, SPEED, ACCEL, FWD_IN, REV_IN, etc.
- (4) There are many parameters related to pulse axis, they can be set and checked through relative instructions, please see "axis parameter and axis status" of "Basic", or see "RTSys/View/Axis parameter".

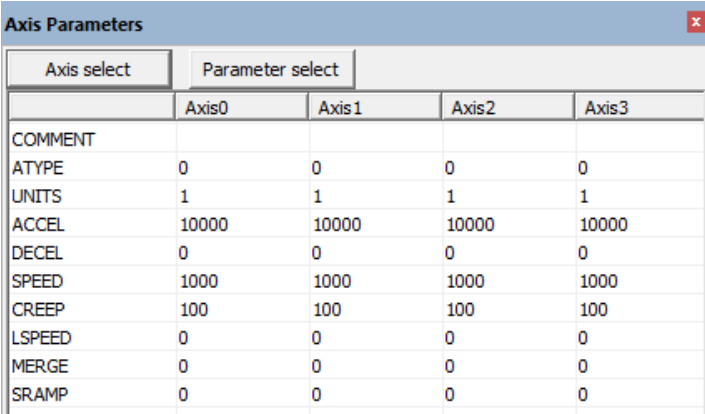

Axis select	Axis0	Axis1	Axis2	Axis3
Parameter select				
COMMENT				
ATYPE	0	0	0	0
UNITS	1	1	1	1
ACCEL	10000	10000	10000	10000
DECEL	0	0	0	0
SPEED	1000	1000	1000	1000
CREEP	100	100	100	100
LSPEED	0	0	0	0
MERGE	0	0	0	0
SRAMP	0	0	0	0

- (5) Control corresponding motion through "View – Manual".

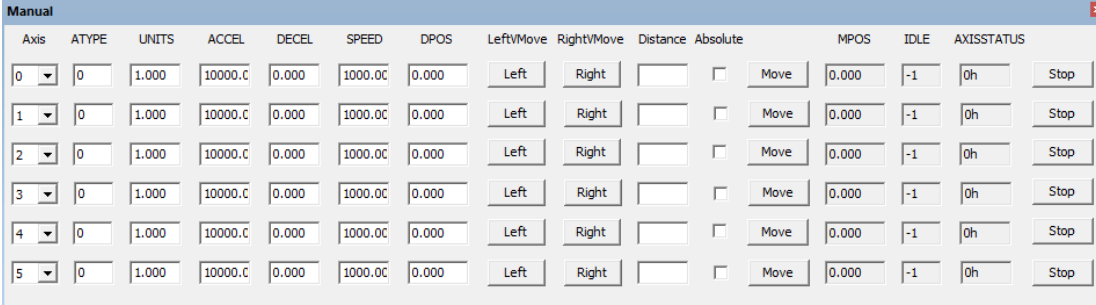

Axis	ATYPE	UNITS	ACCEL	DECEL	SPEED	DPOS	Left/Move	Right/Move	Distance	Absolute	MPOS	IDLE	AXISSTATUS		
0	0	1.000	10000.0	0.000	1000.00	0.000	Left	Right		<input type="checkbox"/>	Move	0.000	-1	0h	Stop
1	0	1.000	10000.0	0.000	1000.00	0.000	Left	Right		<input type="checkbox"/>	Move	0.000	-1	0h	Stop
2	0	1.000	10000.0	0.000	1000.00	0.000	Left	Right		<input type="checkbox"/>	Move	0.000	-1	0h	Stop
3	0	1.000	10000.0	0.000	1000.00	0.000	Left	Right		<input type="checkbox"/>	Move	0.000	-1	0h	Stop
4	0	1.000	10000.0	0.000	1000.00	0.000	Left	Right		<input type="checkbox"/>	Move	0.000	-1	0h	Stop
5	0	1.000	10000.0	0.000	1000.00	0.000	Left	Right		<input type="checkbox"/>	Move	0.000	-1	0h	Stop

Refer to BASIC Routine:

BASE(0,1)	'select axis 0 and axis 1
ATYPE = 1,1	'set axis 0 and axis as pulse axes
UNITS = 1000,1000	'set pulse amount as 1000 pulses
SPEED = 10,10	'set axis speed as 10*1000 pulse/s
ACCEL = 1000,1000	'set axis acceleration as 1000*1000 pulse/s/s
FWD_IN = -1,-1	'prohibit using axis positive hardware position limit
REV_IN = -1,-1	'prohibit using axis negative hardware position limit
MOVE(10) AXIS(0)	'axis 0 moves distance of 10*1000 pulses in positive
MOVE(-20) AXIS(0)	'axis 0 moves distance of 20*1000 pulses in negative

Chapter IV Expansion Module

The controller can expand digital IO, analog IO, pulse axis and other resources through CAN bus or EtherCAT bus. That is, it can use together with ZIO series CAN expansion modules, EIO series EtherCAT expansion modules, or ZMIO310 series vertical expansion modules. For details, please refer to corresponding user manual.

4.1. CAN Bus Expansion

[ZIO series expansion modules](#) or [ZMIO310-CAN coupler with sub modules](#) can be used.

Connect control card to CAN bus expansion modules, when the eighth bit of the DIP switch of the expansion module is turned to ON, which indicates that a 120-ohm resistor has been connected, but needs to connect one 120-ohm resistor externally. When connecting multiple CAN expansion modules, you only need to dial ON for the eighth digit of the last expansion module, which means please do not dial bit-8 of other modules.

4.1.1. CAN Bus Expansion Wiring

The ZIO expansion module is powered by the dual power supply. Except the main power supply, an additional IO power supply is required to supply independent power for IO. Both the main power supply and the IO power supply use 24V DC power supply. For ZAIO, it only needs to connect to the main power supply.

To prevent interference, separate the IO power supply from the main power supply.

Please select the expansion module according to the requirements, and select IO mapping or axis mapping according to the resources of the expansion module.

Wiring reference of connection between ZIO expansion module and control card and standard wiring of CAN bus are shown as below:

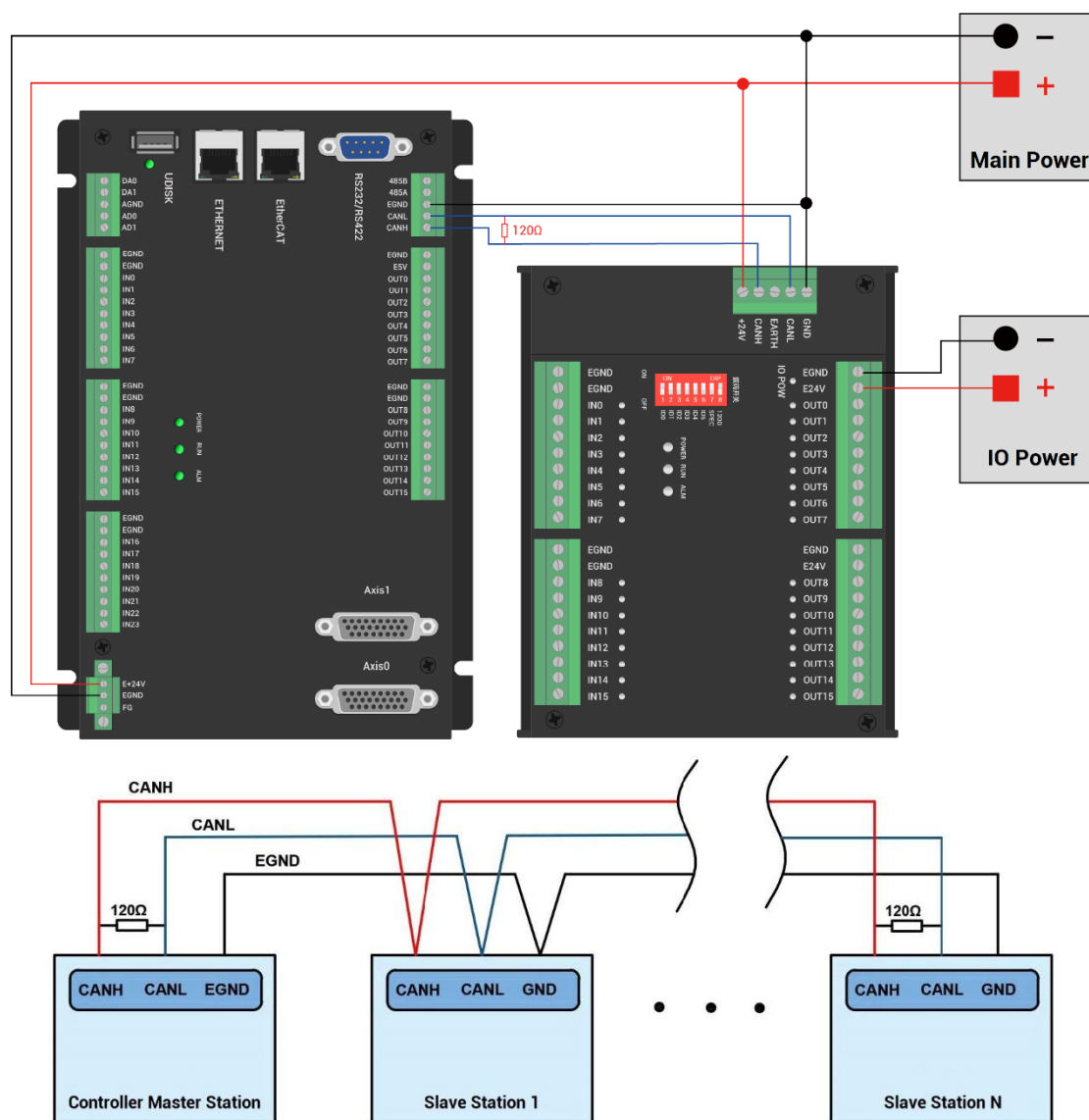

→ **Wiring Note:**

- ❖ ZMC308E controller uses the single power, and ZIO expansion module uses dual-power. When using, main power supply of expansion module and main power supply of controller can share one power. When they use different power supplies, controller power EGND needs to connect to expansion module power GND, otherwise CAN may be burnt out.
- ❖ When connecting multiple ZIO expansion modules on the CAN bus, a 120-ohm resistor needs to be connected in parallel between the CANL and CANH terminals, for the ZIO expansion module that is with 8-digit dialing codes, the terminal resistor can be realized by dialing the code (DIP).

4.1.2. CAN Bus Expansion Resource Mapping



The ZCAN expansion module generally has an 8-bit DIP switch, dial ON to take effect, and the meaning of the DIP is as follows:

1-4: they are used for ZCAN expansion module IO address mapping, the corresponding value is 0-15.

5-6: CAN communication speed, corresponding value is 0-3, four different speeds are optional.

7: reserved.

8: 120-ohm resistor, dial ON means a 120-ohm resistor is connected between CANL and CANH.

The IO numbers of the entire control system cannot be repeated, and existed numbers must be avoided when mapping resources. And the DIP switch must be dialed before power-on, if re-dial after power-on, it is invalid. It needs to be powered on again to take effect.

Dial 1-4 to select the CAN address, and the controller sets the IO number range of the corresponding expansion module according to the CAN DIP address. When each is dialed as OFF, the corresponding value is 0, when it is ON, it corresponds to a value of 1, and the address combination value = dial 4 \times 8 + dial code 3 \times 4 + dial code 2 \times 2 + dial code 1.

Dial code 5-6 to select CAN bus communication speed, speed combination value=dial code 6 \times 2 + dial code 5 \times 1, the combined value range is 0-3.

The corresponding speeds are as follows:

DIP 5-6 combination value	CANIO_ADDRESS high 8-bit value	CAN communication speed
0	0 (corresponds to decimal 128)	500KBPS (default value)
1	1 (corresponds to decimal 256)	250KBPS
2	2 (corresponding to decimal 512)	125KBPS
3	3 (corresponding to decimal 768)	1MBPS

The controller side sets the CAN communication speed through the CANIO_ADDRESS

command. There are also four speed parameters that can be selected. The communication speed must be consistent with the communication speed of the expansion module that corresponds to the combination value, then they can communicate with each other.

The factory default communication speed is 500 KBPS on both sides, there is no need to set this, unless you need to change the speed.

The CANIO_ADDRESS command is a system parameter, and it can set the master-slave end of CAN communication. The default value of the controller is 32, that is, CANIO_ADDRESS=32 is the master end, and the slave end is set between 0-31.

The CAN communication configuration can be viewed in the "State the Controller" window.

→ IO Mapping:

the CAN expansion module uses bit1-4 of the DIP switch. According to the number of currently included IO points(the largest number in IN and OP must include IO point in the axis interface), use the bit 1-4 to set the ID, so as to determine the number range of IO to be expanded.

If the controller itself contains 28 INs and 16 OPs, then the starting address set by the first extended board should exceed the maximum value of 28. According to below rule, the dial code should be set to the combination value 1 (binary combination value 0001, from right to left, dial code 1-4, at this time dial 1 is set to ON, and the others are set to OFF), the IO number on the expansion board = the expansion board number value + the initial IO number value, among them, the IOs that are vacant from 29-31 Numbers are not used. Subsequent extended boards continue to confirm the dial settings according to the IO points in turn.

The initial digital IO mapping number starts from 16 and increases in multiples of 16. The distribution of digital IO numbers corresponding to different dial IDs is as follows:

DIP 1-4 combination value	Starting IO No.	Ending IO No.
0	16	31
1	32	47
2	48	63
3	64	79
4	80	95
5	96	111
6	112	127

7	128	143
8	144	159
9	160	175
10	176	191
11	192	207
12	208	223
13	224	239
14	240	255
15	256	271

The initial IO mapping number of the analog AD starts from 8 and increases in multiples of 8. The initial IO mapping number of the analog DA starts from 4 and increases in multiples of 4. The allocation of digital IO numbers corresponding to different dial code IDs is as follows:

DIP 1-4 combination value	Starting AD number	End AD number	Starting DA number	End DA number
0	8	15	4	7
1	16	23	8	11
2	24	31	12	15
3	32	39	16	19
4	40	47	20	23
5	48	55	24	27
6	56	63	28	31
7	64	71	32	35
8	72	79	36	39
9	80	87	40	43
10	88	95	44	47
11	96	103	48	51
12	104	111	52	55
13	112	119	56	59
14	120	127	60	63
15	128	135	64	67

→ Axis Mapping:

When the CAN bus expansion mode is used to expand the pulse axis, ZIO16082M can be selected to expand two pulse axes. These two pulse axes need to be mapped and bound with the axis No., then access.

Extended axes need to perform axis mapping operations, using the `AXIS_ADDRESS` command to map, and the mapping rules are as follows:

`AXIS_ADDRESS(axis No.)=(32*0)+ID`

'the local axis interface of the expansion module AXIS 0

`AXIS_ADDRESS(axis No.)=(32*1)+ID`

'the local axis interface of the expansion module AXIS 1

The ID is the combined value of the DIP bit1-4 of the expansion module. After the mapping is completed and the axis parameters such as `ATYPE` are set, the expansion axis can be used.

Example:

`ATYPE(6)=0` 'set as virtual axis

`AXIS_ADDRESS(6)=1+(32*0)`

'ZCAN expansion module ID 1 axis 0 is mapped to axis 6

`ATYPE(6)=8` 'ZCAN extended axis type, pulse direction stepping or servo

`UNITS(6)=100 0` 'pulse equivalent 1000

`SPEED(6)=100` 'speed 100units/s

`ACCEL(6)=1000` 'acceleration 1000units/s²

`MOVE(100) AXIS(6)` 'extended axis movement 100units

Extended resource viewing:

According to the CAN connection, after the power is turned on, and the wiring resistance dial code is set correctly, the power indication led (`POWER`) and the running indication led (`RUN`), the IO power indication led (`IO POWER`) are on, and the alarm indication led (`ALM`) is off. At the same time, the "Controller" - "State the controller" - "ZCanNodes" in the RTSys software displays the expansion module information and the extended IO number range.

The dial ID and the corresponding resource number when connecting multiple expansion modules are as follows:

Local	432-0(ZMC432)	32	30(0-29)	18(0-17)	0	2(0-1)	
1	48(ZIO1632)	0	16(32-47)	32(32-63)	0	0	
3	26(ZIO16082)	2	16(64-79)	8(64-71)	0	0	
4	10(ZAIO0802)	0	0	0	8(40-47)	2(20-21)	

ALM indicator light is on, please check whether the wiring, resistor and dial setting are correct, and whether the CANIO_ADDRESS command of the controller is set as the master end (32), and whether the CAN communication speed is consistent.

4.2. EtherCAT Bus Expansion

[The EIO expansion modules](#) and [ZMIO310-ECAT are expansion modules](#) used by the EtherCAT bus controller. For example, EIO series can expand the resources of digital IO and pulse axis. When the resources of the controller are insufficient, the EtherCAT bus controller can be connected to multiple EIO expansion modules for expansion, you can view the maximum number of IO expansion points and the maximum number of expansion axes of the controller, and in this way, it supports IO remote expansion.

4.2.1. EtherCAT Bus Expansion Wiring

After the expansion wiring is completed, each EIO expansion module does not need to develop again. It only needs to manually configure the unique IO address and axis address in the EtherCAT master controller, and it can be accessed after the configuration is completed.

The IO address number is set through the bus command NODE_IO, and the program on the controller can access the resources on the expansion module only through the IO number. The configuration of the axis address uses the AXIS_ADDRESS command to map axis number, and when the binding is completed, specify the axis number through the BASE or AXIS command.

When wiring, pay attention that EtherCAT IN is connected to the upper-level module, and EtherCAT OUT is connected to the lower-level module. The IN and OUT ports cannot be mixed.

EIO expansion module wiring reference example:

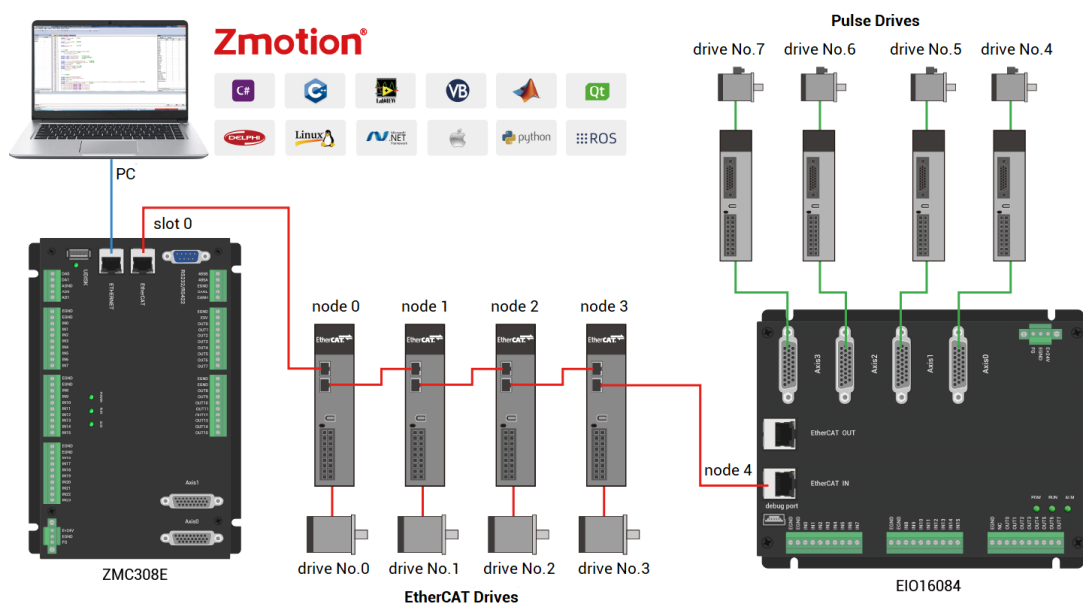

Involved number concepts in above figure are as follows: the bus-related command parameters will use the following numbers:

Slot number (slot):

The slot number refers to the number of the bus interface on the controller, and the slot number of the EtherCAT bus is 0.

Device number (node):

The device number refers to the number of all devices connected to a slot. It starts from 0 and is automatically numbered according to the connection sequence of the devices on the bus. You can view the total number of devices connected to the bus through the `NODE_COUNT(slot)` command.

Drive number:

The controller will automatically identify the drive on the slot, and the number starts from 0, and the number is automatically numbered according to the connection sequence of the drive on the bus.

The drive number is different from the device number. Only the drive device number on the slot is assigned, and other devices are ignored. The drive number will be used when mapping the axis number.

4.2.2. EtherCAT Bus Expansion Resource Mapping

→ IO Mapping:

The program on the controller can access the resources on the expansion module only through the IO number. The IO number of the EtherCAT bus expansion module is set through the bus command NODE_IO, and the input and output are configured at the same time.

When IO mapping, first check the maximum IO number of the controller itself (including the external IO interface and the interface in the pulse axis), and then use the command to set.

If the extended IO coincides with the IO number of the controller itself, the two will work at the same time, so the mapped number of the IO mapping must not be repeated in the entire control system.

IO mapping syntax:

NODE_IO(slot, node) = iobase

slot: slot number, 0-default

node: device number, starting from 0

iobase : mapping the IO start number, the setting result will only be a multiple of 8

Example:

NODE_IO(0,0)=32 'set the IO start number of slot 0 interface device 0 to 32

If device 0 is EIO16084, after configuration according to the above syntax, the IO numbers corresponding to input IN0-15 are 32-47 in turn, the general input port numbers in the axis interface are 48-55, and the drive alarm inputs of axes AXIS 0-3 are 48-51 respectively. The IO numbers corresponding to the output OUT0-7 are 32-39 in sequence, the general output port numbers in the axis interface are 40-47, and the drive enable outputs of the axes AXIS 0-3 are 40-43 respectively.

0	41bh	1918h	0	4	24(32-55)	16(32-47)	0

→ AXIS Mapping:

Before using the axis of the expansion module, you need to use the `AXIS_ADDRESS` command to map the axis number, and the axis mapping also needs to pay attention to the axis number of the entire system cannot be repeated. The mapping syntax of the EIO series extended axis is the same as that of the bus driver.

Axis mapping syntax:

`AXIS_ADDRESS(axis number)=(slot number<<16)+driver number+1`

Example:

`AXIS_ADDRESS(0)=(0<<16)+0+1`

'the first drive on the EtherCAT bus, drive number 0, bound as axis 0

`AXIS_ADDRESS(1)=(0<<16)+1+1`

'the second drive on the EtherCAT bus, drive number 1, bound as axis 1

If the first node is EIO16084, and EIO16084 is connected to drive, then driver 0 here is the first pulse driver connected to EIO16084, otherwise it is the EtherCAT driver.

Chapter V Programming

5.1. Program in RTSys Software

RTSys is a PC-side program development, debugging and diagnostic software for the Zmotion motion controllers. Through it, users can easily edit and configure the controller program, quickly develop applications, diagnose system operating parameters in real time, and debug the running program in real time. What's more, it supports Chinese and English bilingual environments.

In RTSys, there are 4 programming languages for motion control development, Basic, PLC, HMI and C language, they can run multi-tasks among them, especially for Basic, multi-task running can be achieved separately, hybrid programming is also OK with PLC, HMI and C language.

RTSys Downloading Address: https://www.zmotionglobal.com/pro_info_282.html

And related manuals can be found in "Download":

Features
Parameters
System Architecture
Download

Name	Version No	Format	Size	Download
RTSys Development Software	V1.2.02	RAR	148MB	Download
RTSys User Manual V1.2.0	V1.2.0	PDF	5.33MB	Download
RTBasic Programming Manual	V1.1.0	PDF	18.3MB	Download
RTHMI Programming Manual	V1.2.0	PDF	7.23MB	Download
Quick Start	VQuick Start	ZIP	16.1MB	Download
ZVision Basic Programming Manual V1.3.0	V1.3.0	PDF	10.6MB	Download
ZPLC	V1.0	PDF	1.7M	Download

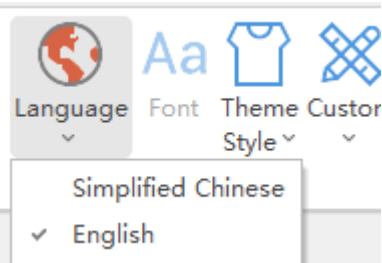
Step	Operations	Display Interface
1	<p>Switch the Language: "Language" – "English", then there will pop</p>	

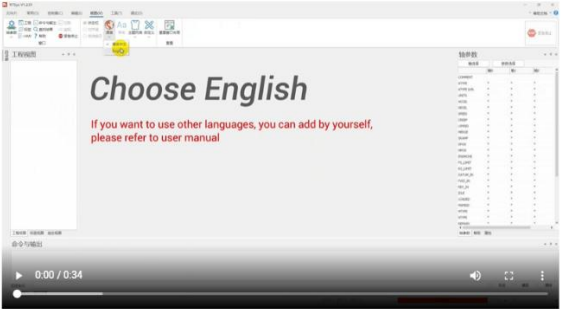
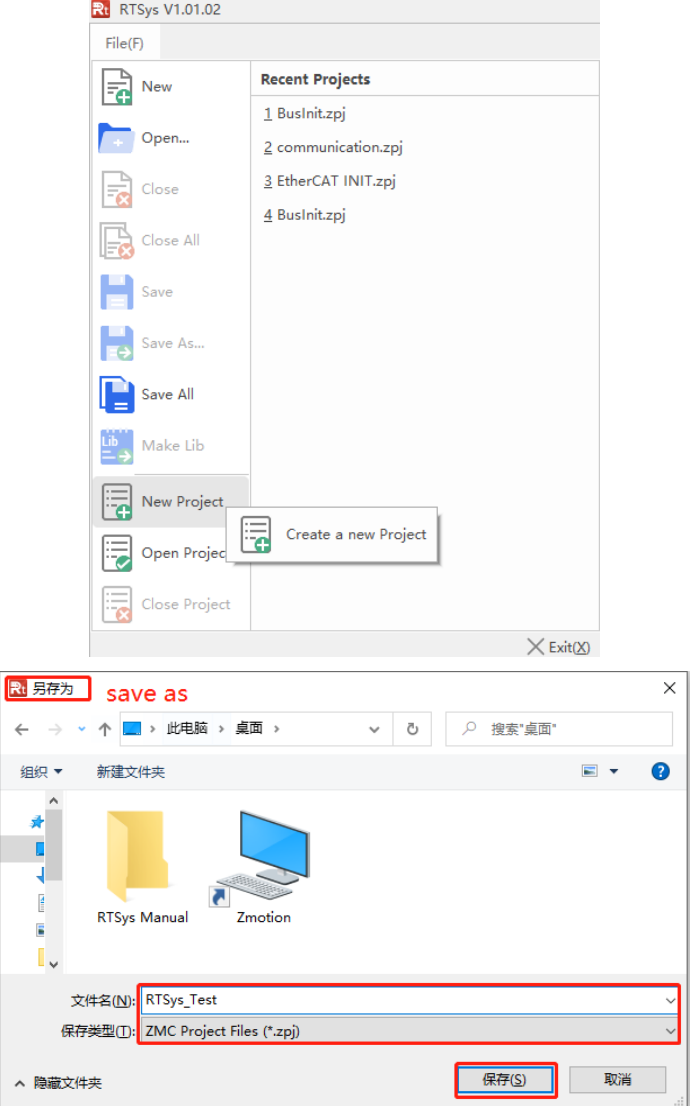
	<p>up one window, click OK, and restart it.</p>	<p style="text-align: center;"><u>Language Switch Video Showing:</u></p> <p>E. How to Switch the Language</p> <p>Find "视图" (the fourth one in the above menu), then find the "语言", choose English, restart RTSys. English RTSys will take effect when opened again.</p> 
<p>2</p>	<p>New Project: "File" – "New Project", Save as window will pop up, then enter file name, save the project file with suffix "zpj".</p>	

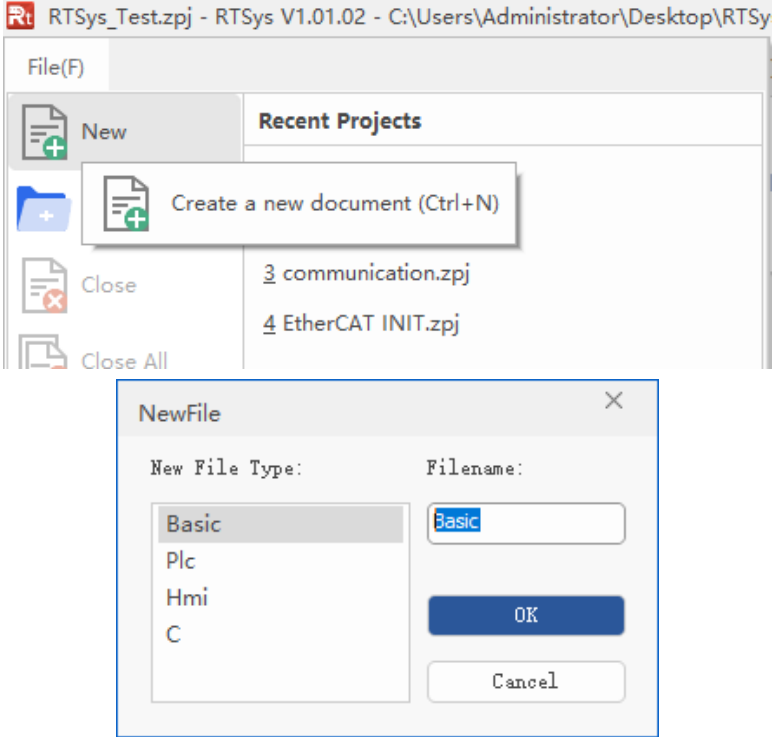
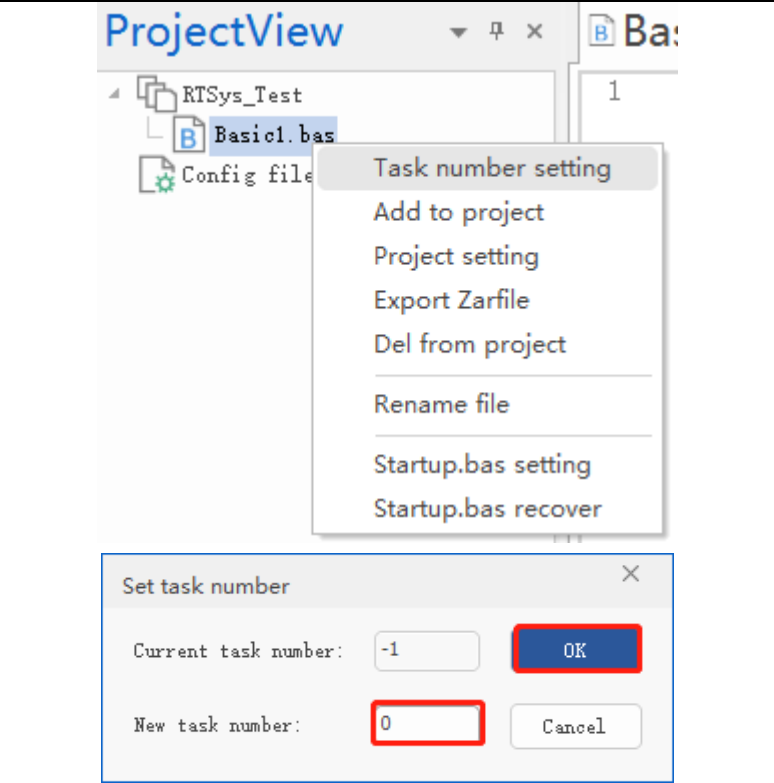
<p>3</p>	<p>New File: "File" – "New File", select file type to build, here select Basic, click "OK".</p>	 <p>The screenshot shows the 'File(F)' menu with 'New' selected. A tooltip for 'New' says 'Create a new document (Ctrl+N)'. Below it, 'Recent Projects' lists 'communication.zpj' and 'EtherCAT INIT.zpj'. The 'NewFile' dialog box is open, showing 'Basic' selected in the 'New File Type' list and 'Basic' in the 'Filename' field. 'OK' and 'Cancel' buttons are visible.</p>
<p>4</p>	<p>Set Auto Run No.: right click the file, open task number setting window, enter task No., which can be any + value, no priority, but not the same.</p>	 <p>The screenshot shows the 'ProjectView' window with a tree view containing 'RTSys_Test', 'Basic1.bas', and 'Config file'. A context menu is open over 'Basic1.bas' with 'Task number setting' selected. Below it, the 'Set task number' dialog box is open, showing 'Current task number' as -1 and 'New task number' as 0. 'OK' and 'Cancel' buttons are visible.</p>

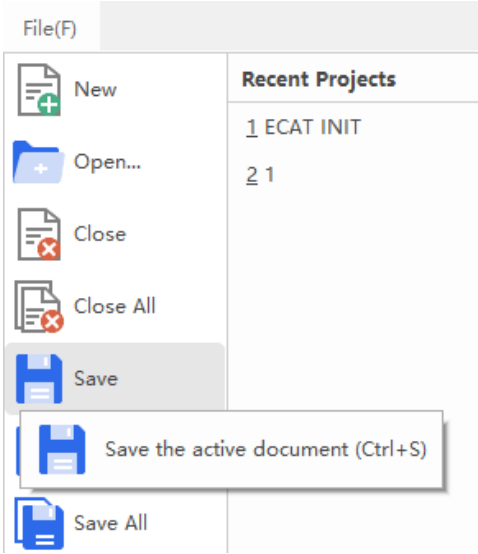
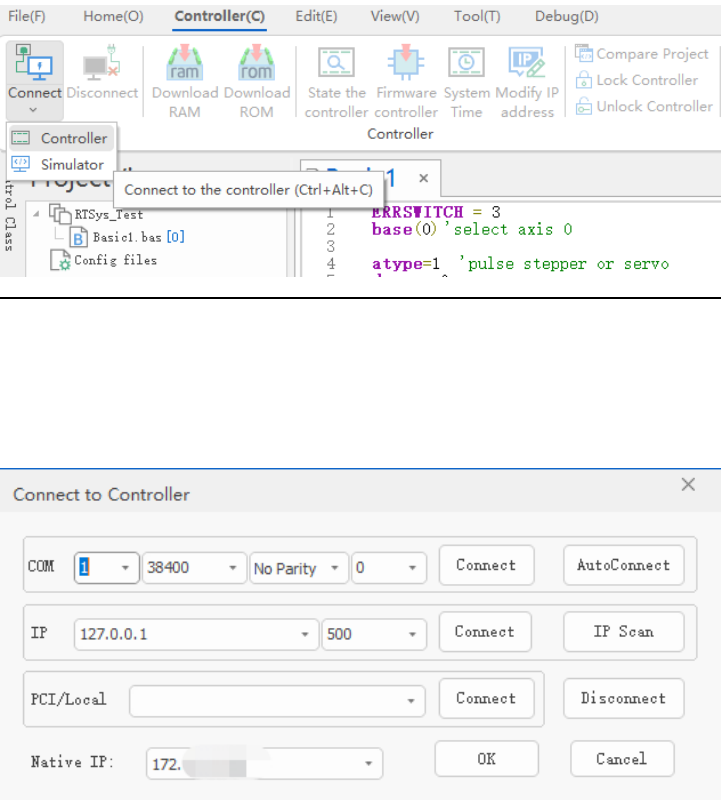
<p>5</p>	<p>Save File: edit the program in program editing window, click "save", new built file will be saved under "zpj." project automatically. "Save all" means all files under this project will be saved.</p>	
<p>6</p>	<p>Connection: Click "controller – connect", if no controller, select connect to simulator. Then, "connect to controller" window will pop up, you can select serial port or net port to connect, select matched serial port parameters or net port IP address, then click "connect".</p>	
<p>7</p>	<p>Download Program into</p>	<ul style="list-style-type: none"> ● RAM: it will not save when power off. ● ROM: it will save data when power off, and when the program

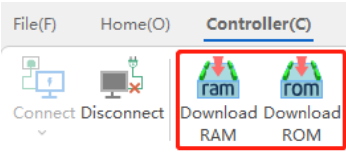
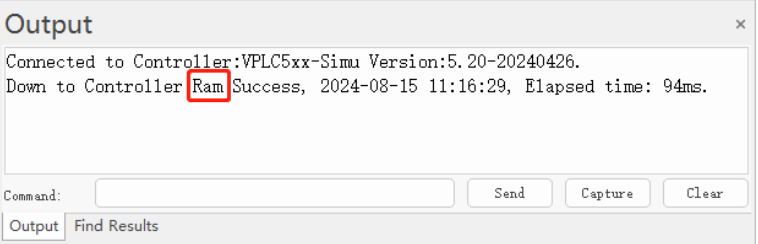
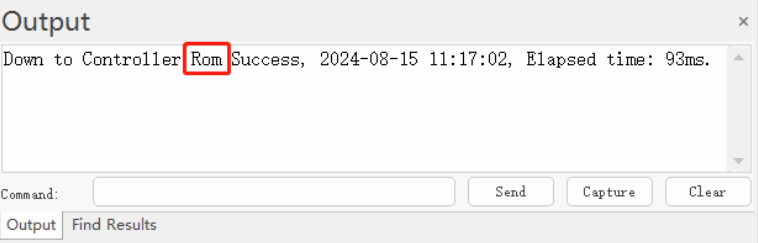
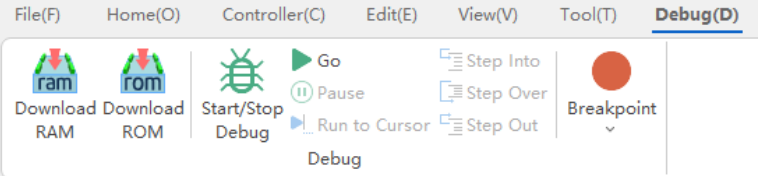
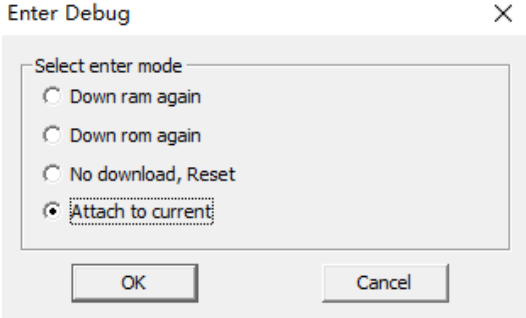
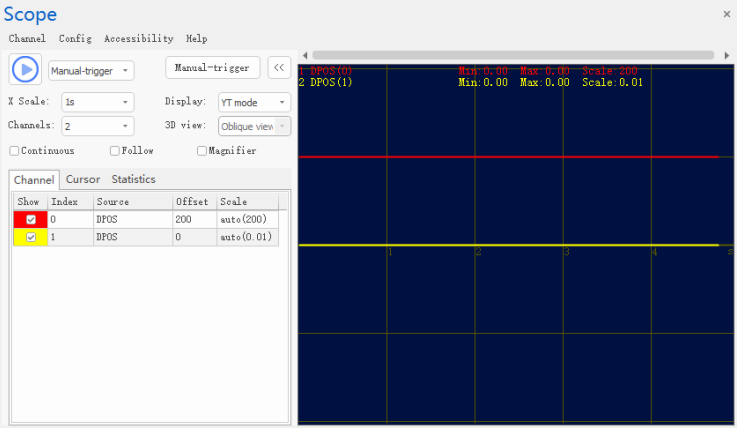
	<p>Controller:</p> <p>“Ram/Rom” – “download RAM / download ROM”, if it is successful, there is print indication, at the same time, program is downloaded into controller and runs automatically.</p>	<p>is connected to controller again, running according to task No.</p>   																		
<p>8</p>	<p>Debug: “Debug” – “Start/Stop Debug” to call “Task” and “Watch” window, because it was downloaded before, here select “Attach the current”.</p>	 																		
<p>9</p>	<p>Scope function:</p> <p>Click “View” – “Scope” to open oscilloscope. It can capture needed data, for debugging.</p>	 <table border="1" data-bbox="579 1760 874 2011"> <thead> <tr> <th>Channel</th> <th>Cursor</th> <th>Statistics</th> </tr> <tr> <th>Show</th> <th>Index</th> <th>Source</th> <th>Offset</th> <th>Scale</th> </tr> </thead> <tbody> <tr> <td><input checked="" type="checkbox"/></td> <td>0</td> <td>DPOS</td> <td>200</td> <td>auto (200)</td> </tr> <tr> <td><input checked="" type="checkbox"/></td> <td>1</td> <td>DPOS</td> <td>0</td> <td>auto (0.01)</td> </tr> </tbody> </table>	Channel	Cursor	Statistics	Show	Index	Source	Offset	Scale	<input checked="" type="checkbox"/>	0	DPOS	200	auto (200)	<input checked="" type="checkbox"/>	1	DPOS	0	auto (0.01)
Channel	Cursor	Statistics																		
Show	Index	Source	Offset	Scale																
<input checked="" type="checkbox"/>	0	DPOS	200	auto (200)																
<input checked="" type="checkbox"/>	1	DPOS	0	auto (0.01)																

Notes:

- When opening an project, choose to open the zpj file of the project. **If only the Bas file is opened, the program cannot be downloaded to the controller.**
- When the project is not created, only the Bas file **cannot be** downloaded to the controller.
- The number 0 in automatic operation represents the task number, and the program runs with task 0, and the task number has no priority.
- If no task number is set for the files in the entire project, when downloading to the controller, the system prompts the following message **WARN: no program set autorun**

5.2. Upgrade Controller Firmware

Firmware upgrade can be achieved by downloading zfm firmware package in RTSys. zfm file is the firmware upgrade package of controller, please select corresponding firmware because different models are with different packages, please contact manufacturer).

How to update:

- a. Open [ZDevelop](#) / [RTSys](#) software, then click "controller – connect", find PCI/LOCAL method, click "connect". If connected, there will be "Connected to Controller: PCIE464 Version: 4.93 – 20231220." In "output" window.
- b. Click "controller – state the controller", find basic info, then current software version can be checked.
- c. Click "controller – update firmware", current controller model and software version can be viewed.
- d. Click "browse", and select saved firmware file, click "update", then one window will pop up, please click "ok".
- e. After that, "connect to controller" window appears again, and please select "PCI/Local" again, and click "connect".
- f. When connection is successful, "firmware update" interface is shown. Now

system enters ZBIOS state, please click "update" again.

- g. When it is loaded, "firmware update" window disappears, now in output window, it shows "Update firmware to Controller Success".
- h. Do step a and step b again, check whether the firmware is updated or not.

5.3. Program in Host-Computer by PC Languages

The controller supports development under various operating systems such as windows, linux, Mac, Android, and wince, and provides dll libraries in various environments such as vc, c#, vb.net, and labview, as shown in the figure below. PC software programming refers to "[Zmotion PC Function Library Programming Manual](#)".



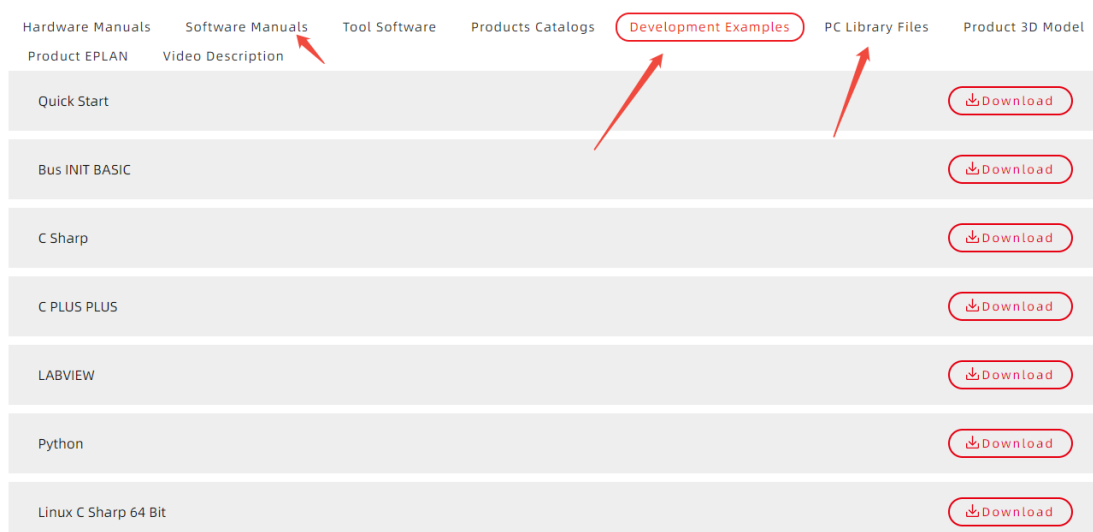

The program developed using the PC software cannot be downloaded to the controller, and it is connected to the controller through the dll dynamic library. The dll library needs to be added to the header file and declared during development.

- Get PC library file, example: https://www.zmotionglobal.com/download_list_17.html

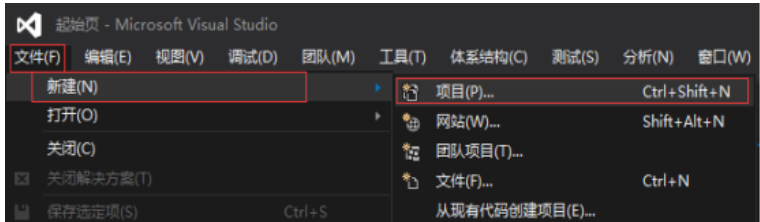
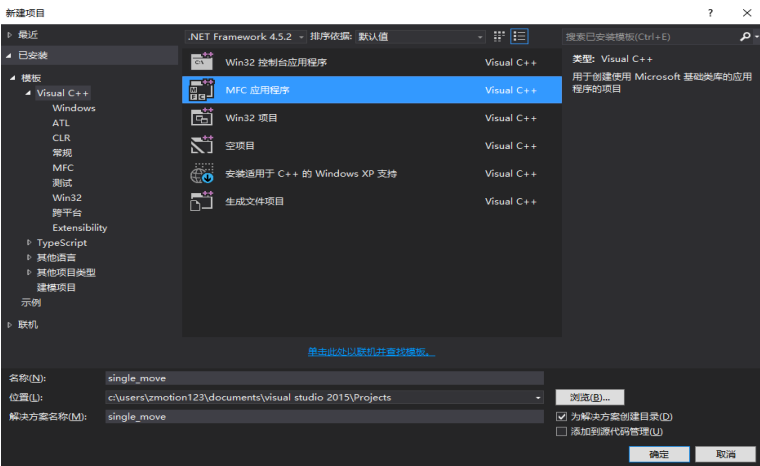

The c++ project development process in VS is as follows:

Step	Operations	Display Interface																												
1	Open VS, click "File" – "New" – "Project".																													
2	Select development language as "Visual C++" and the select program type as "MFC application type".																													
3	Select "Based on basic box", click "next" or "finish".																													
4	Find C++ function library provided by manufacturer. Routine is below (64-bit library)	 <table border="1" data-bbox="564 1659 1326 1850"> <thead> <tr> <th>名称</th> <th>修改日期</th> <th>类型</th> <th>大小</th> </tr> </thead> <tbody> <tr> <td>zauxdll.dll</td> <td>2020/8/11 15:06</td> <td>应用程序扩展</td> <td>2,260 KB</td> </tr> <tr> <td>zauxdll.lib</td> <td>2020/8/11 15:06</td> <td>Object File Library</td> <td>69 KB</td> </tr> <tr> <td>zauxdll2.h</td> <td>2020/8/11 14:56</td> <td>C/C++ Header</td> <td>141 KB</td> </tr> <tr> <td>zmotion.dll</td> <td>2019/3/16 12:21</td> <td>应用程序扩展</td> <td>2,549 KB</td> </tr> <tr> <td>zmotion.h</td> <td>2019/6/3 14:41</td> <td>C/C++ Header</td> <td>39 KB</td> </tr> <tr> <td>zmotion.lib</td> <td>2019/3/16 12:21</td> <td>Object File Library</td> <td>51 KB</td> </tr> </tbody> </table>	名称	修改日期	类型	大小	zauxdll.dll	2020/8/11 15:06	应用程序扩展	2,260 KB	zauxdll.lib	2020/8/11 15:06	Object File Library	69 KB	zauxdll2.h	2020/8/11 14:56	C/C++ Header	141 KB	zmotion.dll	2019/3/16 12:21	应用程序扩展	2,549 KB	zmotion.h	2019/6/3 14:41	C/C++ Header	39 KB	zmotion.lib	2019/3/16 12:21	Object File Library	51 KB
名称	修改日期	类型	大小																											
zauxdll.dll	2020/8/11 15:06	应用程序扩展	2,260 KB																											
zauxdll.lib	2020/8/11 15:06	Object File Library	69 KB																											
zauxdll2.h	2020/8/11 14:56	C/C++ Header	141 KB																											
zmotion.dll	2019/3/16 12:21	应用程序扩展	2,549 KB																											
zmotion.h	2019/6/3 14:41	C/C++ Header	39 KB																											
zmotion.lib	2019/3/16 12:21	Object File Library	51 KB																											
5	Copy all DLL related library files under the above path to the newly created project.																													

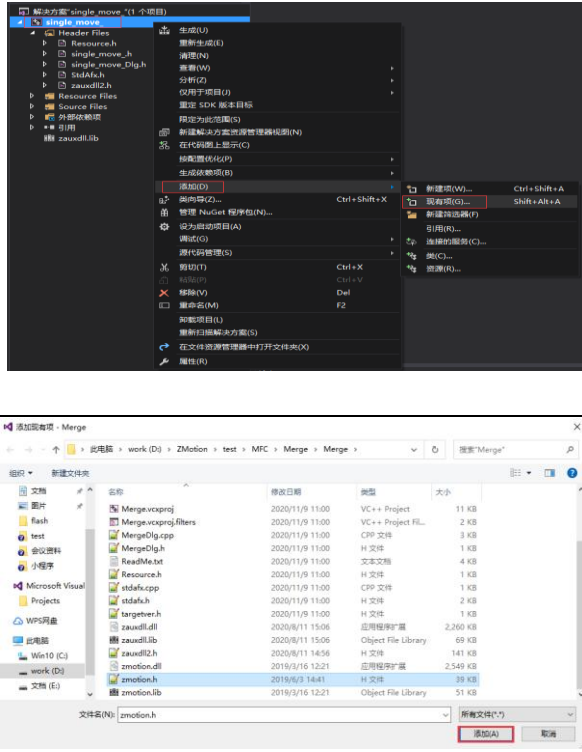
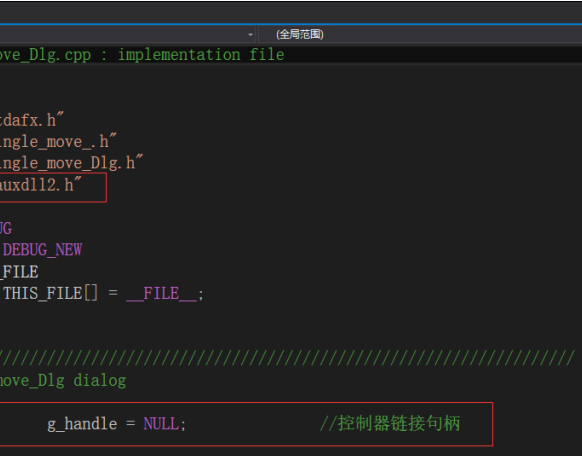
<p>6</p>	<p>Add a static library and related header files to the project. Static library: zauxdll.lib, zmotion.lib Related header files: zauxdll2.h, zmotion.h</p>	<p>1) Right-click the header file first, and then select: "Add" → "Existing Item". 2) Add static libraries and related header files in sequence in the pop-up window.</p>	
<p>7</p>	<p>Declare the relevant header files and define the controller connection handle, so far the project is newly created.</p>		

Chapter VI Operation and Maintain

The correct operation and maintenance of the device can not only guarantee and extend the life cycle of the equipment itself, but also take technical management measures according to the pre-specified plan or the corresponding technical conditions to prevent equipment performance degradation or reduce the probability of equipment failure.

6.1. Regular Inspection and Maintenance

The working environment has an impact on the device. Therefore, it is usually inspected regularly based on the inspection cycle of 6 months to 1 year. The inspection cycle of the device can be appropriately adjusted according to the surrounding environment to make it work within the specified standard environment.

Check item	Check content	Inspection standards
power supply	Check whether the voltage is rated	DC 24V (-5%~5%)
surroundings	Whether the ambient temperature is within the specified range (when installed in the cabinet, the temperature inside the cabinet is the ambient temperature)	-10°C - 55°C
	Whether the ambient humidity is within the specified range (when installed in the cabinet, the humidity in the cabinet is the ambient humidity)	10%-95% non-condensing
	Is there direct sunlight	No
	With or without droplets of water, oil, chemicals, etc.	No
	Whether there is dust, salt, iron filings, dirt	No
	Whether there is corrosive gas	No
	Whether there are flammable and	No

	explosive gases or articles	
	Whether the device is subjected to vibration or shock	Should be within the range of vibration resistance and impact resistance
	Is the heat dissipation good	Keep good ventilation and heat dissipation
Installation and Wiring Status	Whether the basic unit and the expansion unit are installed firmly	The mounting screws should be tightened without loosening
	Whether the connecting cables of the basic unit and the expansion unit are fully inserted	The connection cable cannot be loosened
	Are the screws of the external wiring loose	Screws should be tightened without loosening
	Whether the cable is damaged, aged, cracked	The cable must not have any abnormal appearance

6.2. Common Problems & Solutions

Problems	Suggestions
Motor does not rotate.	<ol style="list-style-type: none"> 1. Check whether the ATYPE of the controller is correct. 2. Check whether hardware position limit, software position limit, alarm signal work, and whether axis states are normal. 3. Check whether motor is enabled successfully. 4. Confirm whether pulse amount UNITS and speed values are suitable. If there is the encoder feedback, check whether MPOS changes. 5. Check whether pulse mode and pulse mode of drive are matched. 6. Check whether alarm is produced on motion controller station or drive station. 7. Check whether the wiring is correct. 8. Confirm whether controller sends pulses normally.

The position limit signal is invalid.	<ol style="list-style-type: none"> 1. Check whether the limit sensor is working normally, and whether the "input" view can watch the signal change of the limit sensor. 2. Check whether the mapping of the limit switch is correct. 3. Check whether the limit sensor is connected to the common terminal of the controller.
No signal comes to the input.	<ol style="list-style-type: none"> 1. Check whether the limit sensor is working normally, and whether the "input" view can watch the signal change of the limit sensor. 2. Check whether the mapping of the limit switch is correct. 3. Check whether the limit sensor is connected to the common terminal of the controller.
The output does not work.	<ol style="list-style-type: none"> 1. Check whether IO power is needed. 2. Check whether the output number matches the ID of the IO board.
POWER led is ON, RUN led is OFF.	<ol style="list-style-type: none"> 1. Check whether the power of the power supply is sufficient. At this time, it is best to supply power to the controller alone, and restart the controller after adjustment. 2. Check whether the ALM light flickers regularly (hardware problem).
RUN led is ON, ALM led is ON.	<ol style="list-style-type: none"> 1. Program running error, please check RTSys error code, and check application program.
Fail to connect controller to PC through serial port.	<ol style="list-style-type: none"> 1. Check whether the serial port parameters are modified by the running program, you can check all the current serial port configurations through ?*SETCOM. 2. Check whether the serial port parameters of the PC match the controller. 3. Open the device manager and check whether the serial driver of the PC is normal.
CAN expansion module cannot be connected.	<ol style="list-style-type: none"> 1. Check the CAN wiring and power supply circuit, whether the 120 ohm resistor is installed at both

	<p>ends.</p> <ol style="list-style-type: none"> 2. Check the master-slave configuration, communication speed configuration, etc. 3. Check the DIP switch to see if there are multiple expansion modules with the same ID. 4. Use twisted-pair cables, ground the shielding layer, and use dual power supplies for severe interference (the main power supply of the expansion module and the IO power supply are separately powered)
<p>Fail to connect controller to PC through net port.</p>	<ol style="list-style-type: none"> 1. Check IP address of PC, it needs to be at the same segment with controller IP address. 2. Check controller IP address, it can be checked and captured after connection through serial port. 3. When net port led is off, please check wiring. 4. Check whether controller power led POWER and running indicator led RUN are ON normally. 5. Check whether the cable is good quality, change one better cable to try again. 6. Check whether controller IP conflicts with other devices. 7. Check whether controller net port channel ETH are all occupied by other devices, disconnect to other devices, then try again. 8. When there are multiple net cards, don't use other net cards, or change one computer to connect again. 9. Check PC firewall setting. 10. Use "Packet Internet Groper" tool (Ping), check whether controller can be Ping, if it can't, please check physical interface or net cable. 11. Check IP address and MAC address through arp-a.